

Proportional pressure reducing valves of the series VMY allow the variable adjustment of the reduced pressure from 0 bar up to the nominal pressure.

The valve consists of a spool type main stage and a proportionally operated pilot stage. The desired pressure can be variably set corresponding to the command signal specified on the amplifier. The proportional solenoid converts the current of the amplifier into force on the valve poppet of the pilot stage.

Typical applications are pressure systems, test equipment, or counterweight systems. The optimum performance can be achieved in combination with the digital amplifier module PCD00A-400 for open loop systems or with PWDXXA-40\* for closed loop systems.

**Function VMY\*K06**

With the proportional solenoids de-energized the main spring forces the main spool into the neutral position. Port A is connected to port T. Thus the reduced pressure only depends on the back pressure in the external drain pipe and/or the tank pressure and can accordingly be reduced down to 0 bar. The pressure present in the P line delivers the pilot oil to the pilot stage via a flow control valve.

When the proportional solenoid is energized, the pilot pressure is increased in the pilot pressure area, and the main spool moves against the spring until the connection P - A opens. The regulation of the reduced pressure on connection A takes place by the constant comparison of the actual pressure and the reference pressure of the pilot stage.



VMY\*K06

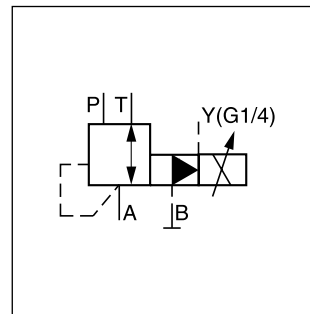

VMY\*K06

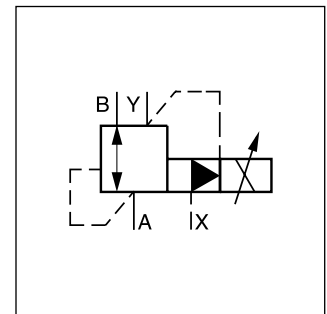

VMY\*K10

**4**

**VMY\*K10**

The valve spool is designed so that the connection B-A is open in the neutral position and is closed in the working position.

**VMY\*K06N**

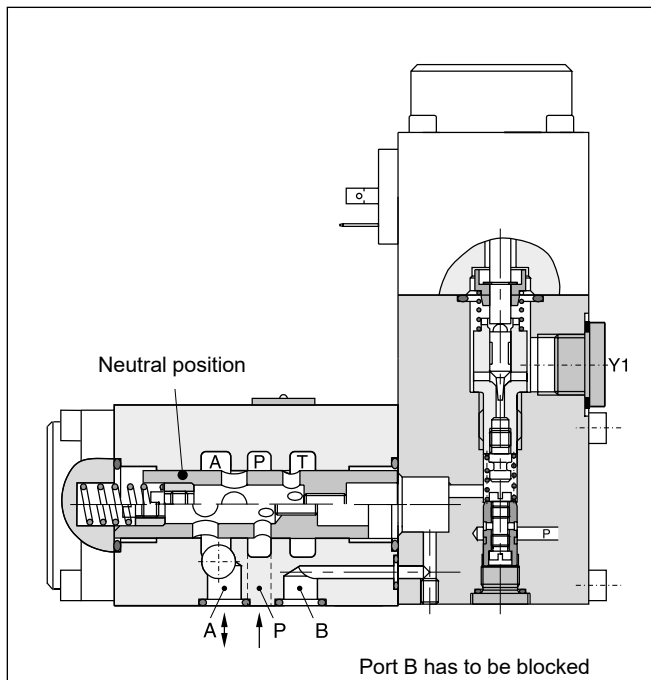

**VMY\*K10**

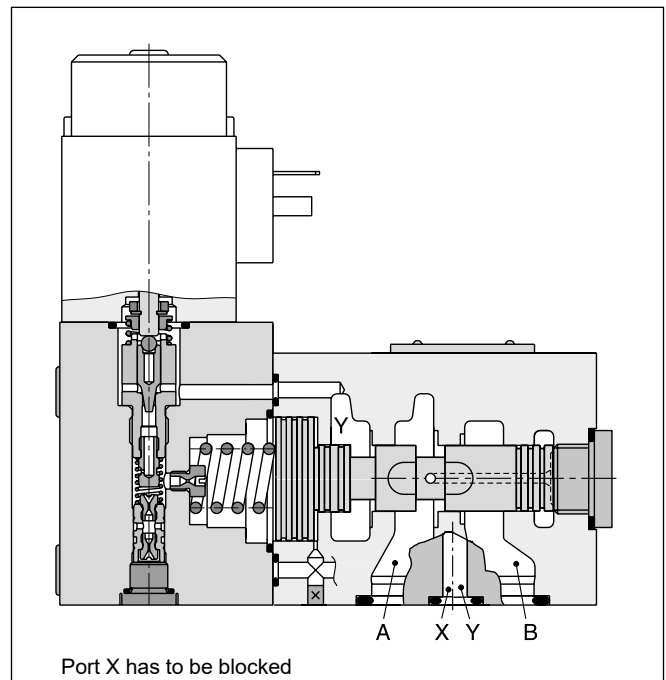

Ordering Code / Technical Data

Ordering code

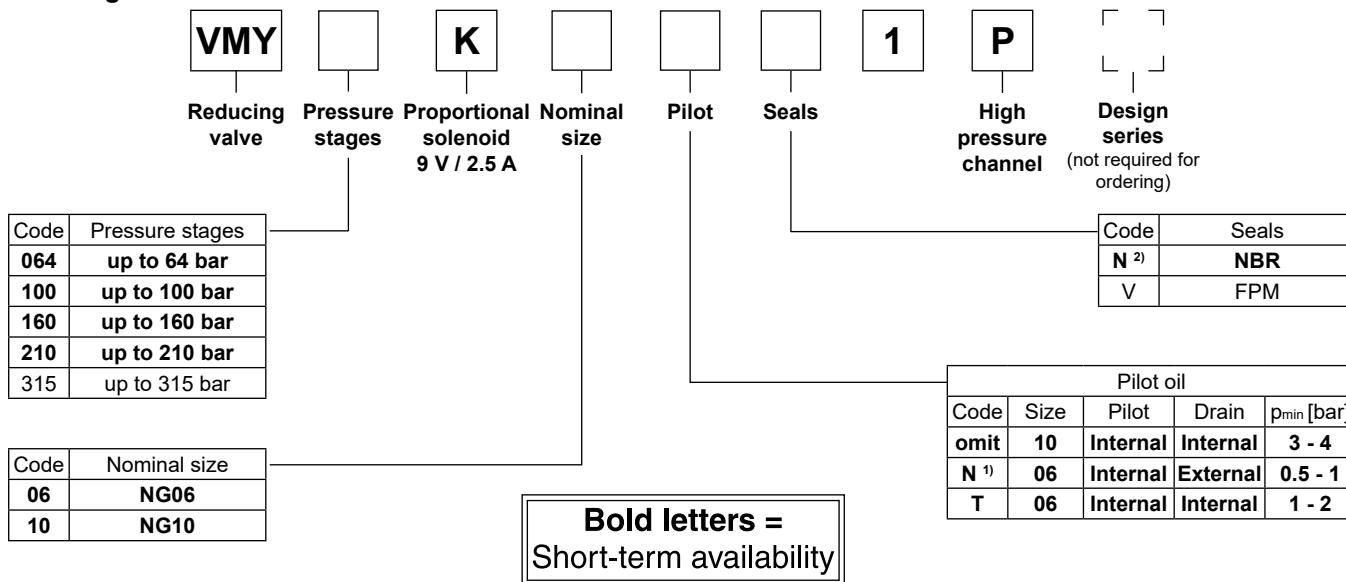

4

Technical data

| General                                       |   |
|---|---|
| Design  | 3 way proportional reducing valve, pilot operated, spool design   |
| Nominal size                                  | <b>06 (DIN NG06/CETOP 03/NFPA D03)</b> <b>10 (DIN NG10/CETOP 05/NFPA D05)</b>   |
| Interface                                     | Subplate mounting according to ISO 5781   |
| Actuation                                     | Proportional solenoid   |
| Mounting position                             | unrestricted  |
| Ambient temperature [°C]                      | -20 ... +60   |
| MTTF <sub>D</sub> value [years]               | 75  |
| Weight [kg]                                   | 2.8 5   |
| Hydraulics                                    |   |
| Max. operating pressure [bar]                 | Size 06:<br>Ports P, A 315; Port T, Y depressurized; port B has to be blocked<br>Size 10:<br>Ports A, B 350; Port Y depressurized; port X has to be blocked |
| Pressure stages [bar]                         | 64, 100, 160, 210, 315  |
| Nominal flow [l/min]                          | 40 160  |
| Fluid   | Hydraulic oil according to DIN 51524  |
| Viscosity permitted [cSt] / recommended [cSt] | 20 ... 400<br>30 ... 80   |
| Fluid temperature [°C]                        | -20...+70 (NBR: -25...+70)  |
| Filtration                                    | ISO 4406 (1999); 18/16/13   |
| Linearity [%]                                 | See characteristic pressure curves ±3.5 at > 15 % p <sub>nom</sub>  |
| Repeatability [%]                             | <±2   |
| Hysteresis [%]                                | <3  |
| Response time [ms]                            | <150 <200   |
| Electrical                                    |   |
| Duty ratio [%]                                | 100 ED  |
| Protection class                              | IP65 in accordance with EN 60529 (with correctly mounted plug-in connector)   |
| Nominal voltage [VDC]                         | 9   |
| Max. current [A]                              | 2.7   |
| Nom. current [A]                              | 2.5   |
| Ambient temperature [°C]                      | -20...+70   |
| Coil resistance [Ohm]                         | -2.1 (at 20 °C)   |
| Solenoid connection                           | Connector as per EN 175301-803  |
| Power amplifier, recommended                  | PCD00A-400  |

<sup>1)</sup> Connection on port Y1 or Y2.

<sup>2)</sup> Not for NG06.

**NG06 Characteristic pressure lines  $p = f(U_{set})$**

Setting range max. 64 bar

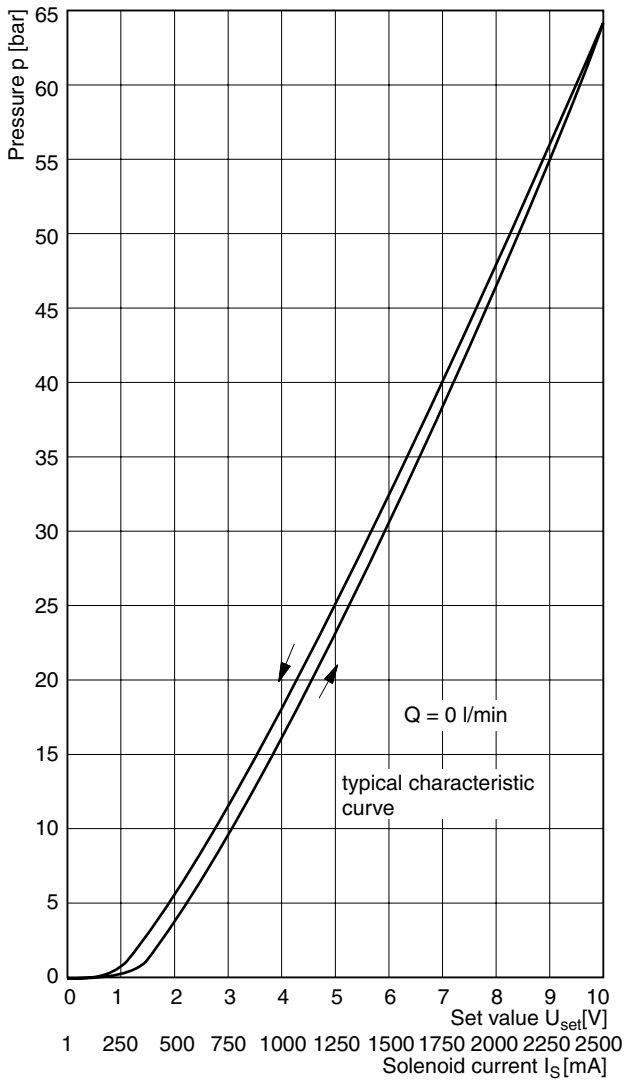

Setting range max. 210 bar

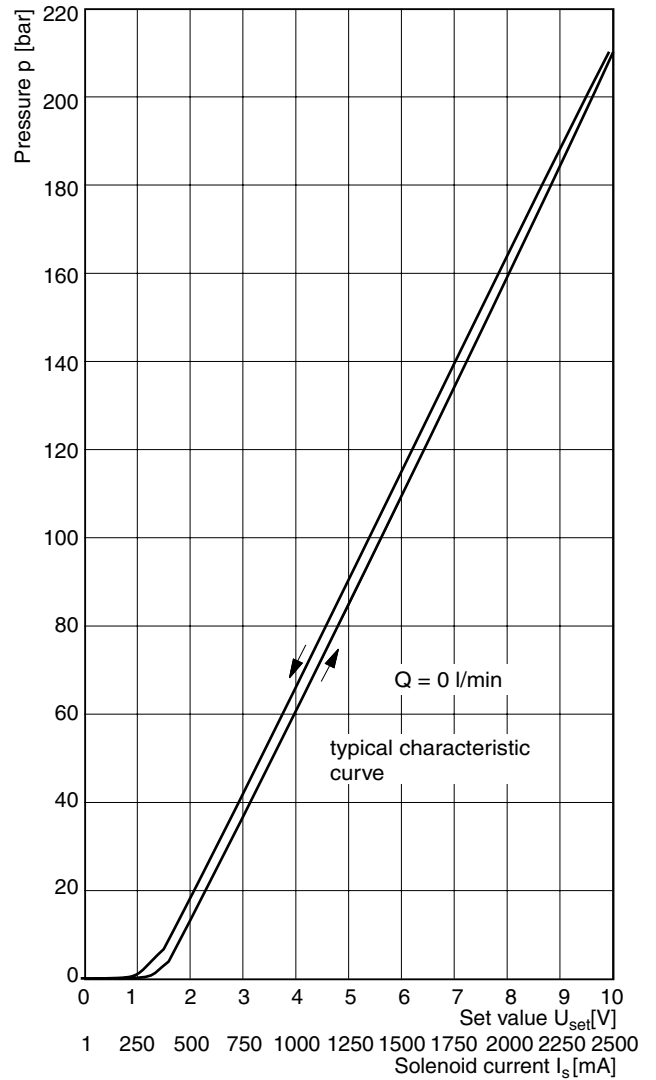

4

**NG06 p/Q characteristics**

Setting range max. 64 bar

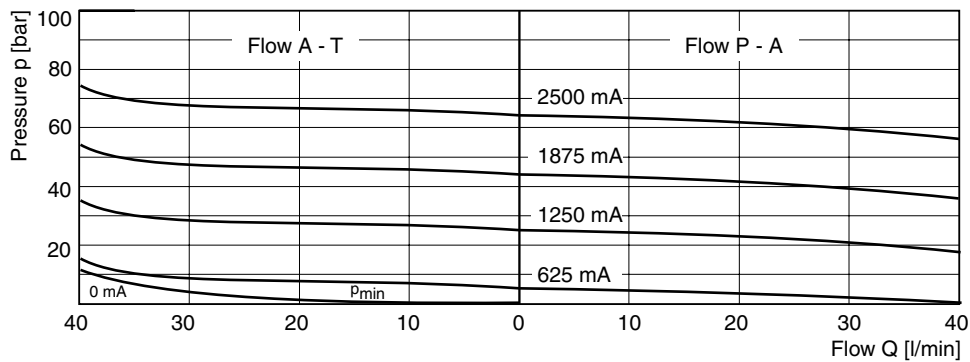

All characteristic curves measured with HLP46 at 50 °C.

**NG06 p/Q characteristics**

**Setting range max. 100 bar**

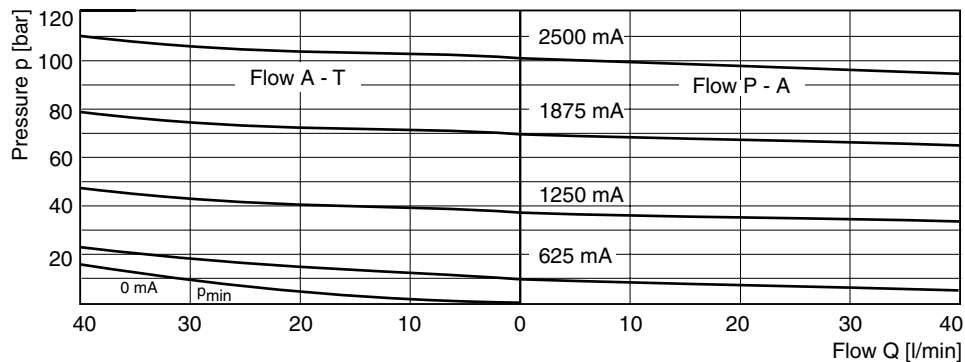

**4**

**Setting range max. 160 bar**

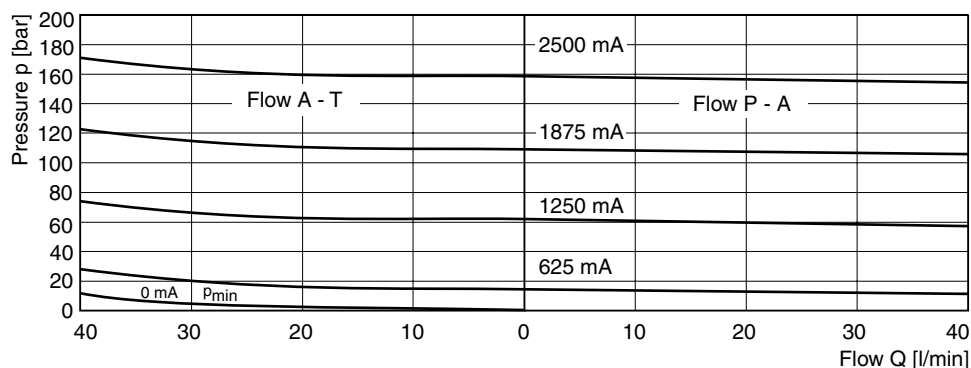

**Setting range max. 210 bar**

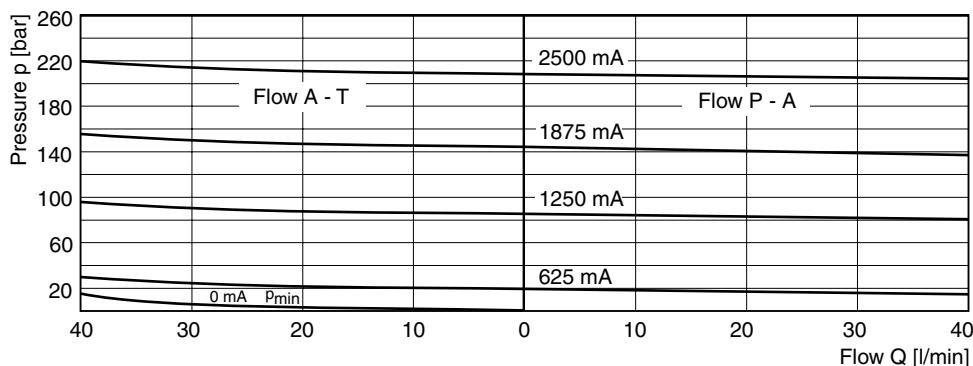

**Setting range max. 315 bar**

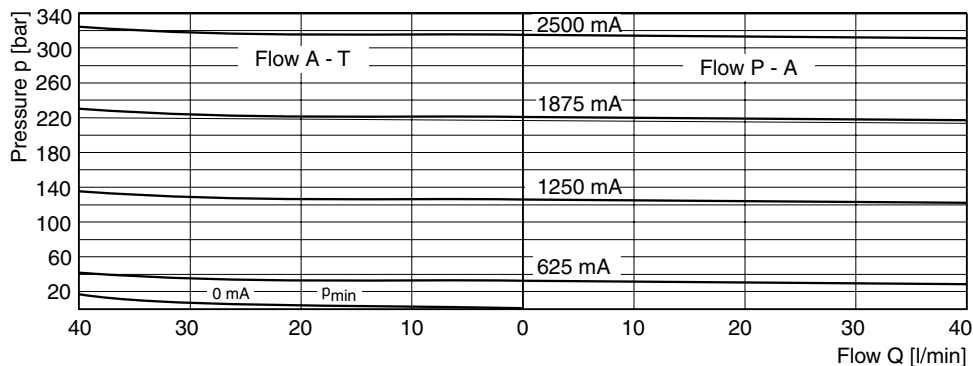

All characteristic curves measured with HLP46 at 50 °C.

**Step response**

Typical curve

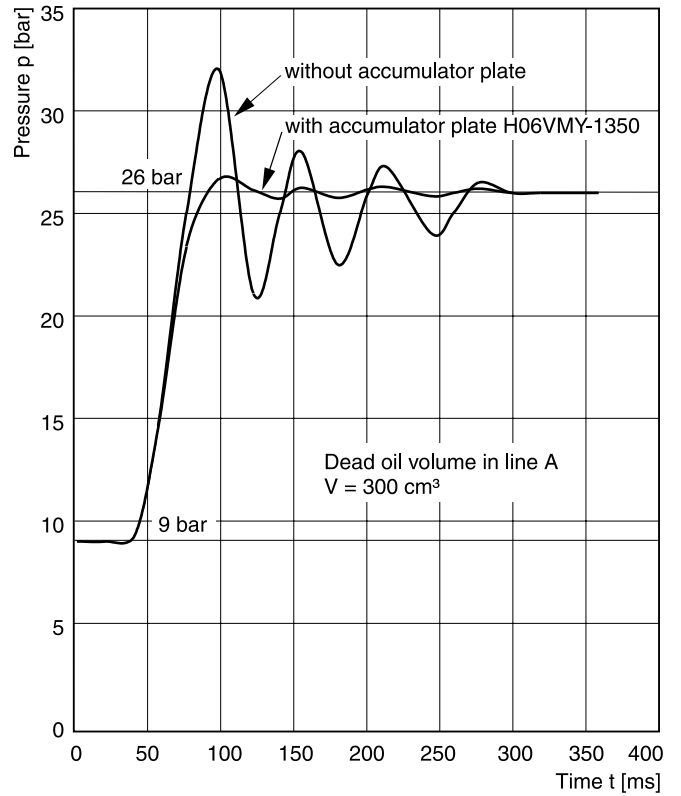
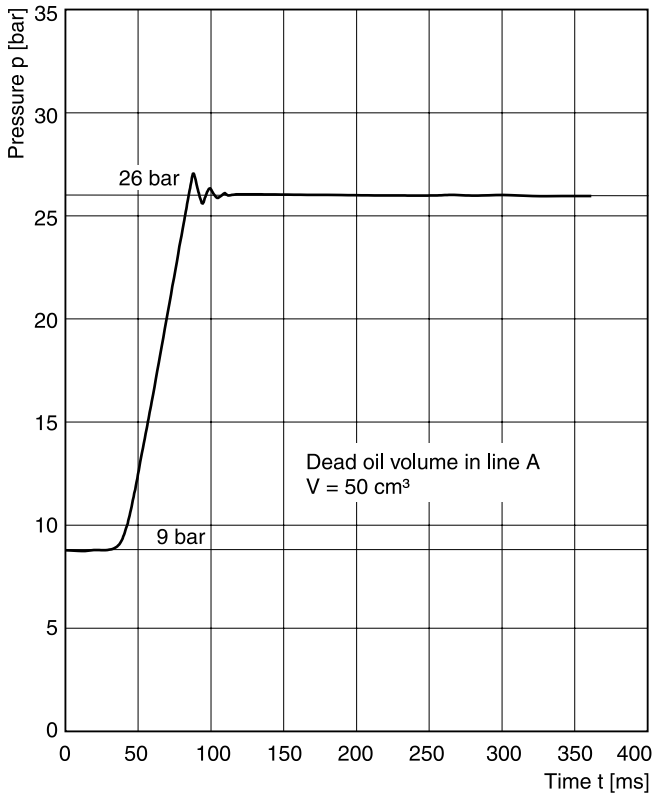

All characteristic curves measured with HLP46 at 50 °C.

**4**

**Accumulator plate H06VMY-1350**

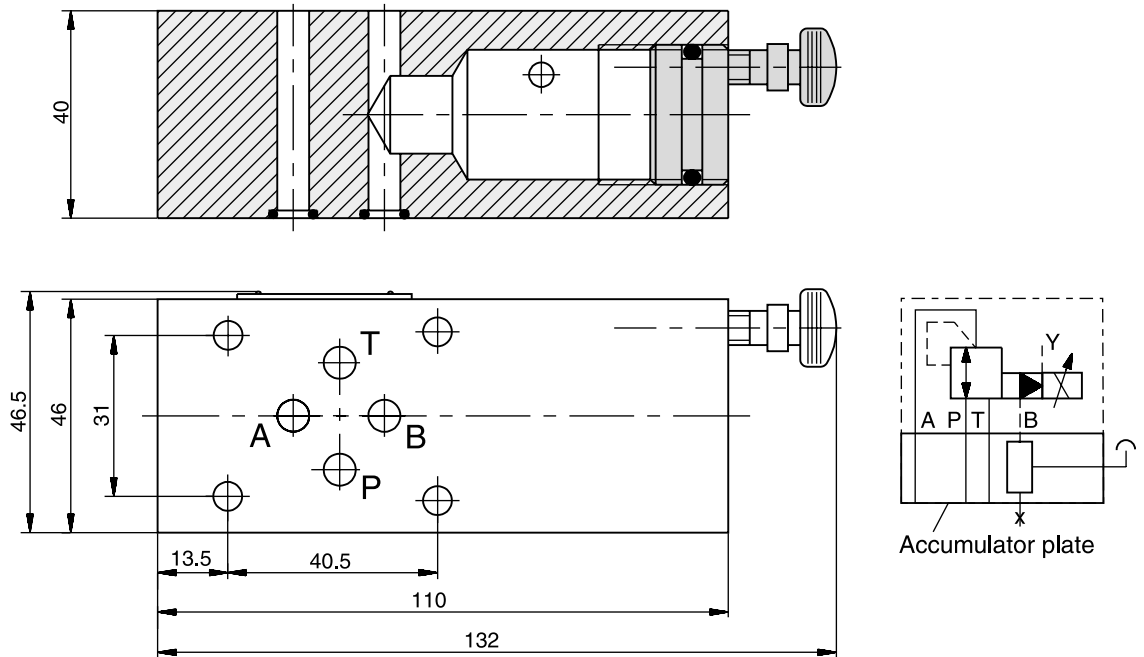

**NG10 p/Q characteristics**

for pilot oil supply from high pressure channel P

**Setting range max. 64 bar**

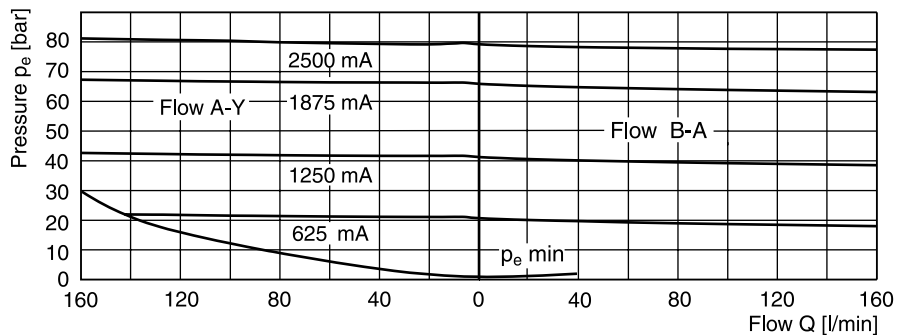

**Setting range max. 100 bar**

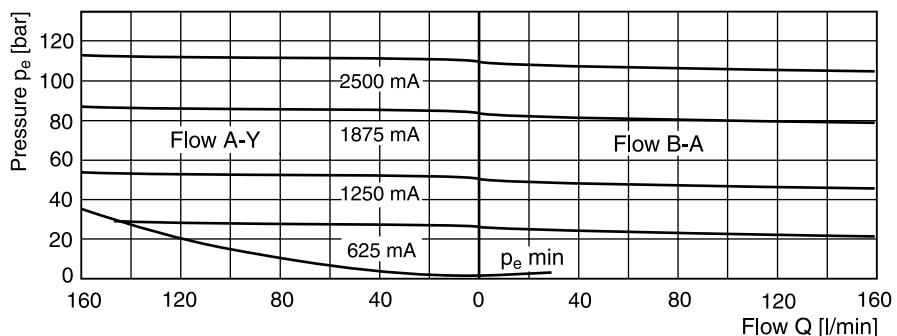

**Setting range max. 160 bar**

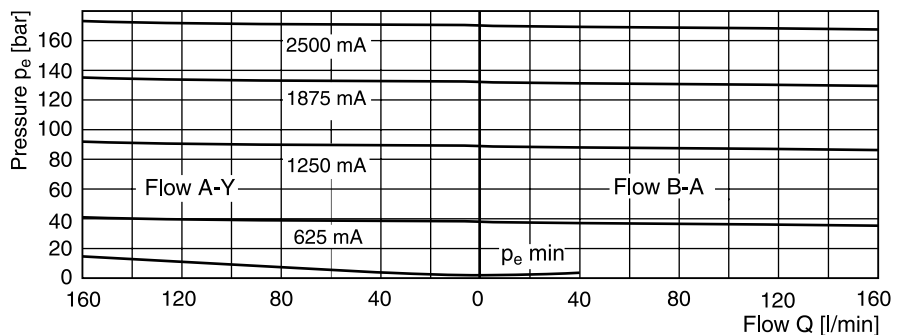

**Setting range max. 210 bar**

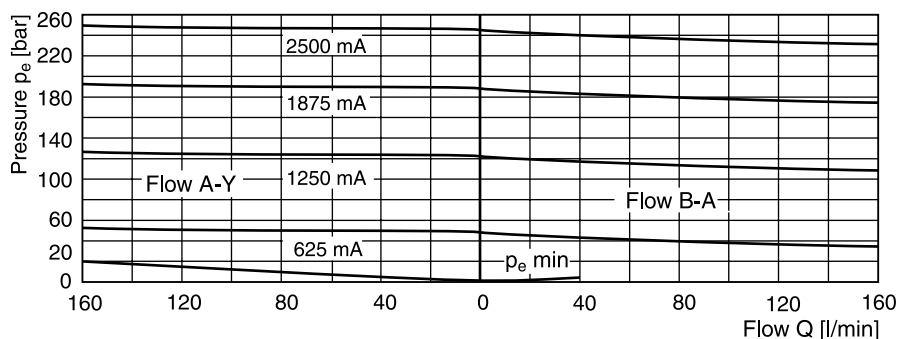

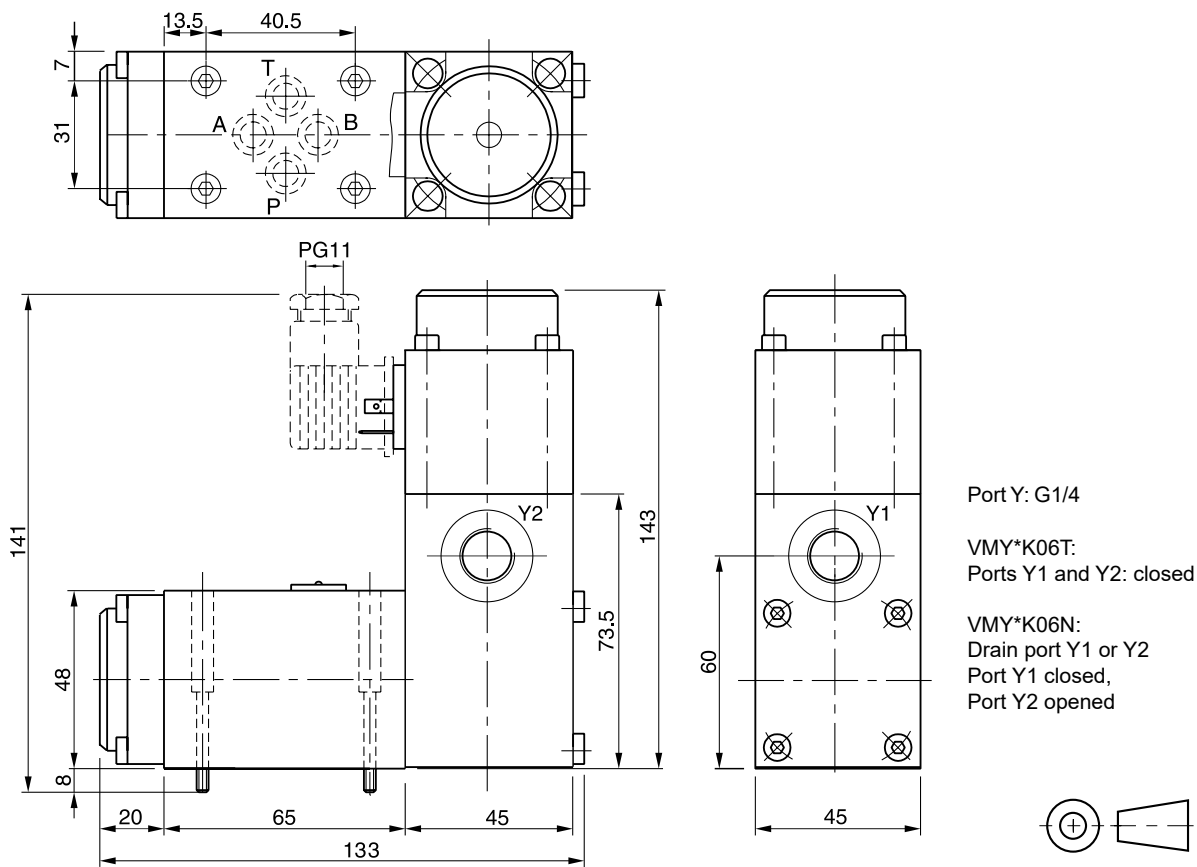

All characteristic curves measured with HLP46 at 50 °C.

**NG06**

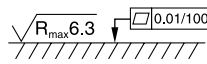

**4**

| Surface finish  | Bolt kit |  |  |  Kit<br>FPM |
|---|----------|---|--|--|
|  | BK375    | 4x M5x30 ISO 4762-12.9  | 7.6 Nm<br>±15 %  | SK-VMY-L06-V   |

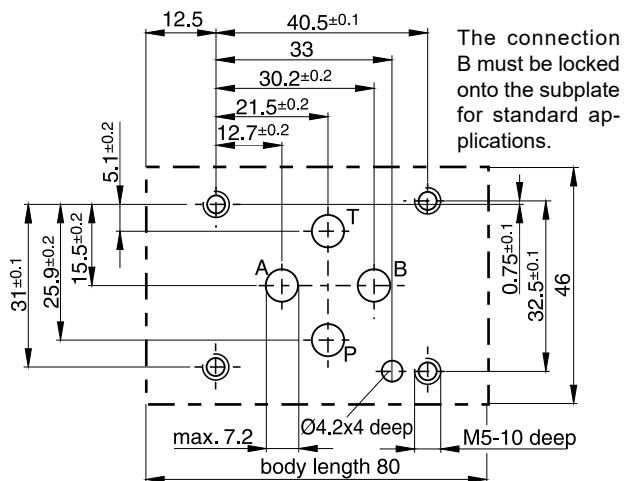

**Mounting pattern ISO 5781-03-04-0-00**

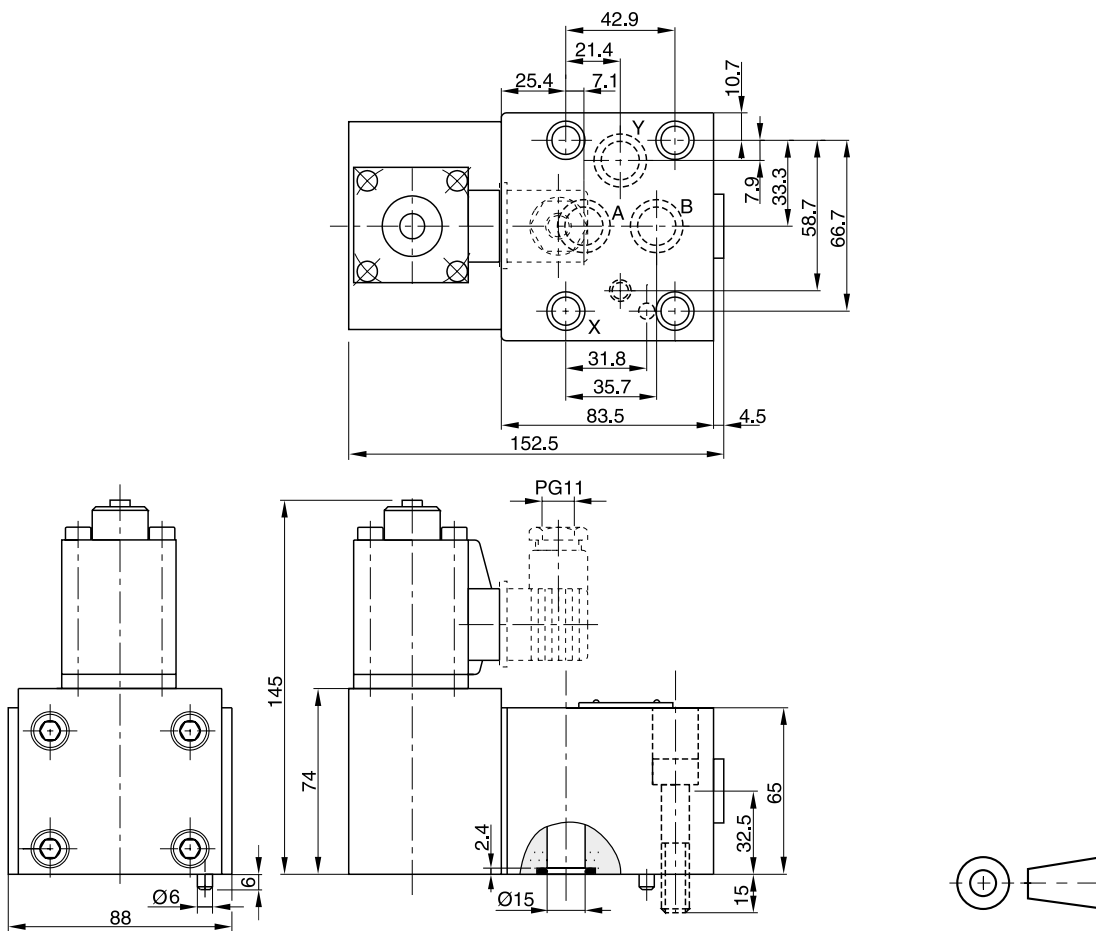

**NG10**

**4**

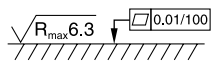

| Surface finish  | Bolt kit |  |  |  Kit<br>FPM |
|---|----------|---|---|--|
|  | BK389    | 4x M10x50 ISO 4762-12.9   | 63 Nm<br>±15 %  | SK-VB/VM-A10V  |

**Mounting pattern ISO 5781-06-07-00 <sup>1)</sup>**

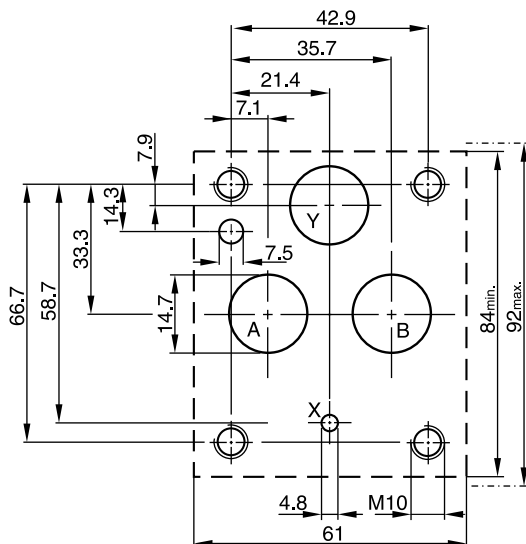

<sup>1)</sup> Deviating from ISO the Y port has Ø 14.7 instead of Ø 4.8.