

SV Bulkhead union

EO 24° cone end

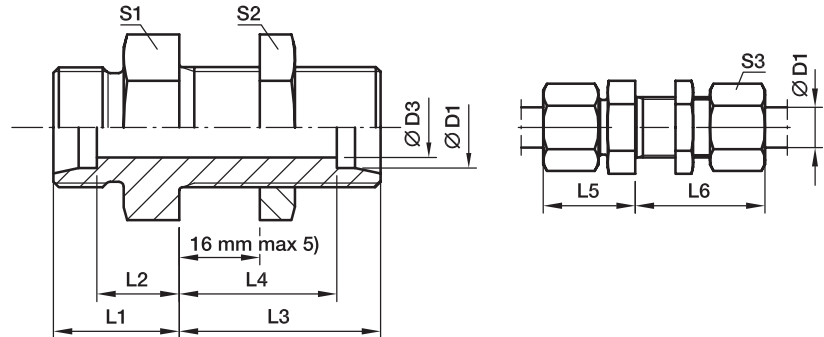

Series	D1	D3	L1	L2	L3	L4	L5	L6	S1	S2	S3	Weight g/1 piece	Order code*	PN (bar) ¹⁾			
														CF	71	MS	
L ³⁾	06	4	14	7.0	34	27.0	22	42	17	17	14	39	SV06LOMD	500	315	200	
	08	6	15	8.0	34	27.0	23	42	19	19	17	50	SV08LOMD	500	315	200	
	10	8	17	10.0	35	28.0	25	43	22	22	19	67	SV10LOMD	500	315	200	
	12	10	17	10.0	36	29.0	25	44	24	24	22	78	SV12LOMD	400	315	200	
	15	12	19	12.0	38	31.0	27	46	27	30	27	128	SV15LOMD	400	315	200	
	18	15	21	13.5	40	32.5	30	49	32	36	32	198	SV18LOMD	400	315	200	
	22	19	24	16.5	42	34.5	33	51	36	41	36	254	SV22LOMD	250	160	100	
	28	24	26	18.5	43	35.5	35	52	41	46	41	335	SV28LOMD	250	160	100	
	35	30	29	18.5	47	36.5	40	58	50	55	50	546	SV35LOMD	250	160	160	
	42	36	30	19.0	47	36.0	42	59	60	65	60	758	SV42LOMD	250	160	160	
	S ⁴⁾	06	4	19	12.0	36	29.0	27	44	19	19	17	65	SV06SOMD	800	630	400
		08	5	20	13.0	36	29.0	28	44	22	22	19	87	SV08SOMD	800	630	400
		10	7	22	14.5	37	29.5	31	46	24	24	22	112	SV10SOMD	800	630	400
		12	8	22	14.5	38	30.5	31	47	27	27	24	141	SV12SOMD	630	630	400
14		10	25	17.0	40	32.0	35	50	30	30	27	180	SV14SOMD	630	630		
16		12	25	16.5	40	31.5	35	50	32	32	30	201	SV16SOMD	630	400	250	
20		16	28	17.5	44	33.5	39	55	41	41	36	462	SV20SOMD	420	400	250	
25		20	32	20.0	47	35.0	44	59	46	46	46	492	SV25SOMD	420	400	250	
30		25	35	21.5	51	37.5	48	64	50	50	50	631	SV30SOMD	420	400	250	
38		32	38	22.0	53	37.0	53	68	65	65	60	1083	SV38SOMD	420	315		

1) Pressure shown = item deliverable

3) L = light series; 4) S = heavy series

5) Bulkhead thickness min.

06–18 L and 06–16 S = 3 mm

22–42 L and 20–38 S = 4 mm

$$\frac{\text{PN (bar)}}{10} = \text{PN (MPa)}$$
Delivery without nut and ring. Information on ordering complete fittings see page I7.

Order code suffixes		
Material	Suffix surface and material	Example
Steel, zinc plated, Cr(VI)-free	CF	SV16SOMDCF
Stainless Steel	71	SV16SOMD71
Brass	MS	SV16SOMDMS

 *Please add the **suffixes** below according to the material/surface required.