

EO® Ermeto Original
SensoControl
Diagnostic
Equipment/
EO Test Points

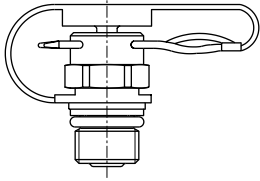
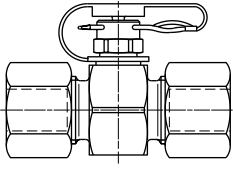
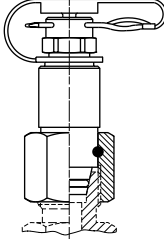
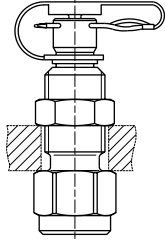
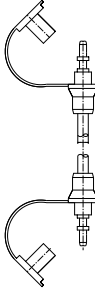
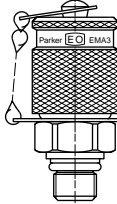
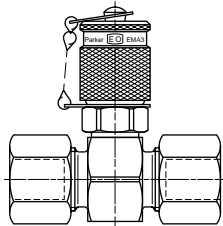
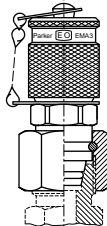
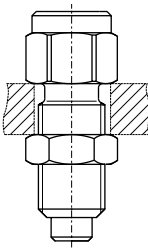
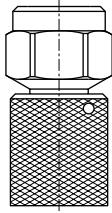
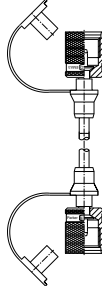

Visual Index

<p>Test points</p>	 <p>EMA1 p. H4</p>	 <p>GMA1 p. H5</p>	 <p>VKA1 p. H6</p>	 <p>MAV-MA1 p. H7</p>
	 <p>SMA1 P. H7</p>	 <p>EMA3 p. H8</p>	 <p>GMA3 p. H9</p>	 <p>VKA3 p. H10</p>
	 <p>MAV-MA3 p. H11</p>	 <p>MAV MD p. H11</p>	 <p>SMA3 p. H11</p>	
<p>SensoControl Product range Diagnosis</p>	<p>p. H12</p>			

EMA 1/EMA 3-Test Point fitting

- For pressure monitoring and checking on high, low and negative pressure systems.
- For bleeding cylinders and hydraulic systems.
- For taking samples.

Advantages:

- | Coupling at system pressure level
- | Leakproof connection before ball valve is open
- | Simple connection to measuring, control and switching devices
- | Self locking metal guard cap

Sealing system of the primary seal:

EMA 1 by ball non-return valve.

EMA 3 by cone seal with O-ring.

The new EMA 3 sealing system guarantees minimum leakage rates even for pneumatic and gas applications (see application).

The screw-on Cap (EMA 3), and pin lock (EMA 1) types both employ an O-ring seal as secondary sealing with the hose attached.

Differences between EMA 1 and EMA 3 types

- a) sealing system (see previous section)
- b) Test hose connection by plug-in coupling in EMA 1
Test hose connection by threaded connection in EMA 3
- c) Working pressures

Working pressure

- EMA 3 types up to 630 bar
- EMA 1 types up to 400 bar
- | Max. working pressure 630 bar for GMA, VKA and EMA... the recommended working pressure of fitting manufacturer has to be applied
- | Joining under pressure up to 400 bar max.

Materials and Temperatures:

- | Metal parts: Steel, Stainless Steel on request
- | Ball: Stainless Steel
- | Seals:
 - NBR (Temperature range -20 to +100°C)
 - FPM (Temperature range -20 to +200°C)
 - EPDM Ethylene Propylene (for Break Fluid) (Temperature range -40 to +150°C)
- | Hose:
 - Polyamide (Temperature range: -35°C ... 100°C max.)

Seals:

- Steel Types NBR (Perbunan)
- Stainless Steel FPM (Viton) only

Media:

- | Suitable for hydraulic oils and other mineral oil based fluids (Please pay attention to the sealing materials used!)
- | For use in conjunction with other liquid media please consult Parker

Approvals

DVGW for EMA3/8X1OR, EMA3/10X1OR, EMA3 1/8NPT, EMA 3 1/4 NPT

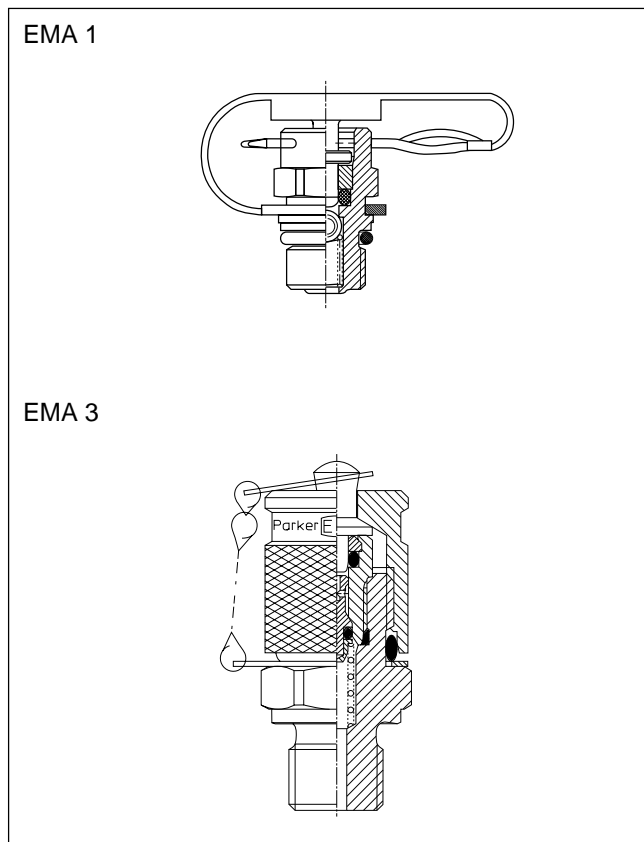

EMA 1 Test point fitting with pin-lock

Male stud thread: BSP, metric

Sealing: O-ring, fig. A, cutting face, fig. B

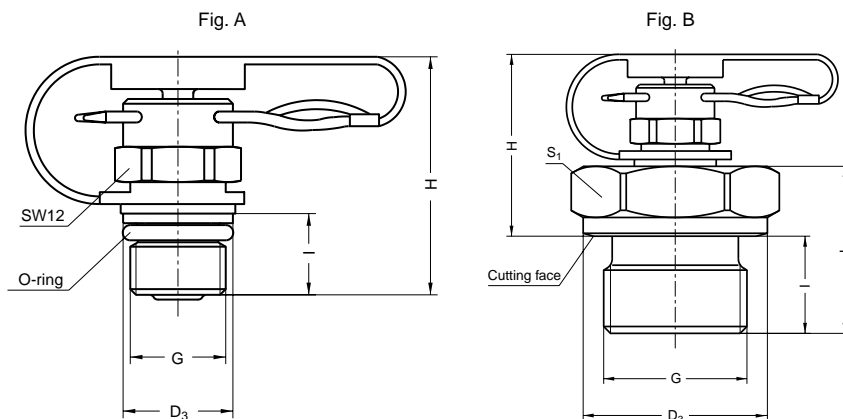

PN (bar)	P _{max} (bar)	G	S ₁	I	L	H	D ₃	Form	Part no.
400	500	M12 ∞ 1.5	19	12.0	27.0	32.0	17.0	B	EMA1/12 ∞ 1.5
400	500	M14 ∞ 1.5	19	12.0	27.0	32.0	19.0	B	EMA1/14 ∞ 1.5
400	500	M16 ∞ 1.5	22	12.0	20.0	25.0	21.0	B	EMA1/16 ∞ 1.5
400	500	G1/8	17	8.0	23.5	32.5	14.0	B	EMA1/1/8
400	500	G1/4	19	12.0	27.0	32.0	18.0	B	EMA1/1/4
400	500	G3/8	22	12.0	22.5	27.5	22.0	B	EMA1/3/8
400	500	G1/2	27	14.0	24.5	27.5	26.0	B	EMA1/1/2
400	500	M8 ∞ 1		8.4		26.0	9.5	A	EMA1/8 ∞ 1 OR
400	500	M10 ∞ 1		8.0		26.0	11.5	A	EMA1/10 ∞ 1 OR
400	500	M10 ∞ 1	17	8.0	23.5	32.5	14.0	B	EMA1/10 ∞ 1

*O-ring 6.07x1.78 for M 8x1
7.8 x1.78 for M 10x1
Material: NBR

GMA 1 Straight Test Point fitting with pin-lock

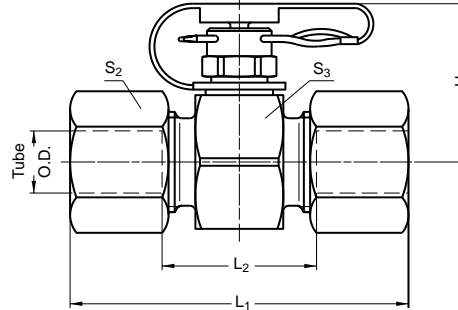

Series	PN (bar)	P _{max} (bar)	Tube O.D.	S ₂	S ₃	L ₁	L ₂	H	DPR steel
L	315	500	6	14	24	51	21	29	GMA1/06L
	315	500	8	17	24	51	21	29	GMA1/08L
	315	500	10	19	24	53	23	29	GMA1/10L
	315	400	12	22	27	53	23	30.5	GMA1/12L
	315	400	15	27	30	55	25	32	GMA1/15L
	315	400	18	32	32	57	24	33	GMA1/18L
	160	250	22	36	36	61	28	35	GMA1/22L
S	400	500	6	17	24	55	25	29	GMA1/06S
	400	500	8	19	24	55	25	29	GMA1/08S
	400	500	10	22	24	57	24	29	GMA1/10S
	400	500	12	24	24	57	24	29	GMA1/12S
	400	500	14	27	27	63	27	30.5	GMA1/14S
	400	500	16	30	30	63	26	32	GMA1/16S
	400	500	20	36	36	69	26	35	GMA1/20S

H

VKA 1 Test point fitting with pin lock for cones

With 24° cone swivel nut connection

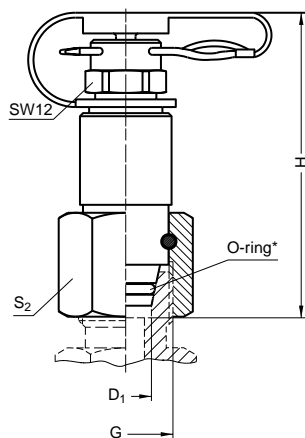

Form A

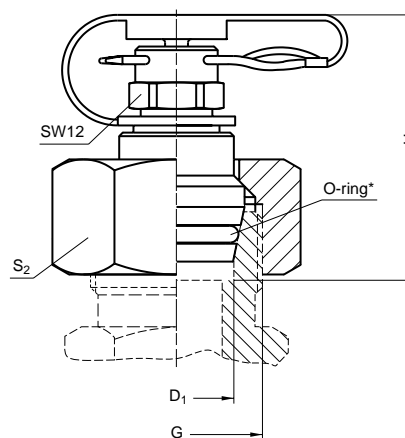

Form B

Series	PN (bar)	P _{max} (bar)	Tube O.D.	D ₁	S ₂	G	H	Form	Part no. ¹ Steel
L	315	500		6	14	M12 _∞ 1.5	48	A	VKA1/06LA3C
	315	500		8	17	M14 _∞ 1.5	49	A	VKA1/08LA3C
	315	500		10	19	M16 _∞ 1.5	50	A	VKA1/10LA3C
	315	400		12	22	M18 _∞ 1.5	51	A	VKA1/12LA3C
	315	400		15	27	M22 _∞ 1.5	39	B	VKA1/15LA3C
	315	400		18	32	M26 _∞ 1.5	38	B	VKA1/18LA3C
S	400	500		6	17	M14 _∞ 1.5	48	A	VKA1/06SA3C
	400	500		8	19	M16 _∞ 1.5	50	A	VKA1/08SA3C
	400	500		10	22	M18 _∞ 1.5	50	A	VKA1/10SA3C
	400	500		12	24	M20 _∞ 1.5	51	A	VKA1/12SA3C
	400	500		14	27	M22 _∞ 1.5	39	B	VKA1/14SA3C
	400	500		16	30	M24 _∞ 1.5	37	B	VKA1/16SA3C
	400	500		20	36	M30 _∞ 2	44	B	VKA1/20SA3C

¹⁾ Supplied complete with nut.

^{*}) O-ring of material (NBR).

MAV-MA 1 Test Point pressure gauge connector with pin-lock
 SMA 1 Test Point high pressure hose with pin-lock

Female thread: BSP
 Sealing: sealing ring DIN 16258

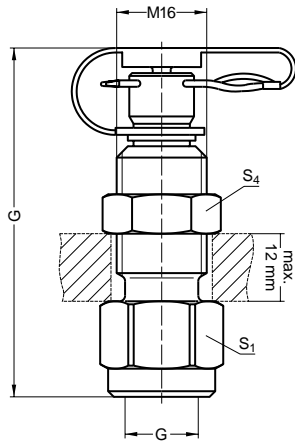

Pressure gauge connector: MAV-MA 1

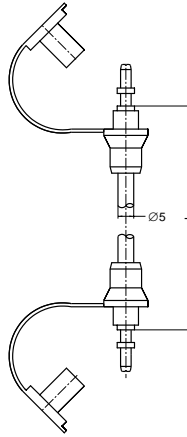

Test hose: SMA 1

PN (bar)	P _{max} (bar)	G	S ₁	S ₄	H	L	Part no.
400	500	G1/4	19	19	61.5		MAV1/4MA1
400	500	G1/2	27	19	72.0		MAV1/2MA1
400	500					400	SMA1-400
400	500					630	SMA1-630
400	500					800	SMA1-800
400	500					1000	SMA1-1000
400	500					1500	SMA1-1500
400	500					2000	SMA1-2000
400	500					2500	SMA1-2500
400	500					3200	SMA1-3200
400	500					4000	SMA1-4000

Note hoses with small diameter:

- Min. bending radius $r = 20$ mm
- Working temperature -20°C up to 100°C (short time to $+120^{\circ}\text{C}$)
- Hoses are to be protected from fire, from sharp-corners and hot objects.

For measuring with liquid pressure media please note:
 Bleed before connecting tube!

Temperature factor of pressur rating:

up to	0°C	122 %
for	30°C	110 %
for	50°C	100 %
for	80°C	86 %
for	100°C	77 %

EMA 3 Test Point with threaded connection M 16∞2

Male thread: BSP, metric

Sealing: O-ring, fig. A/Elastic sealing, fig. B and C, cutting face, fig. D and E

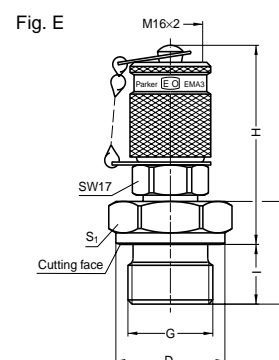
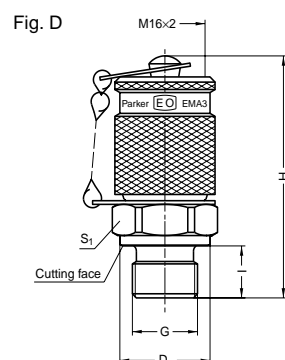
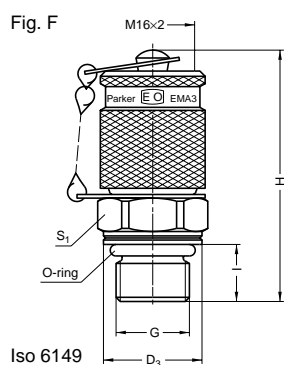
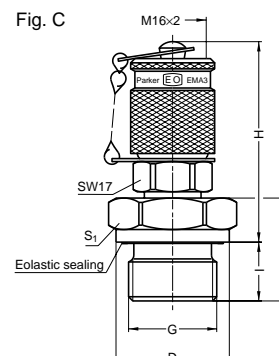
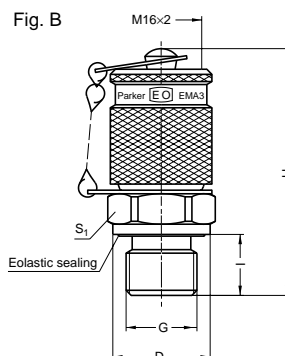
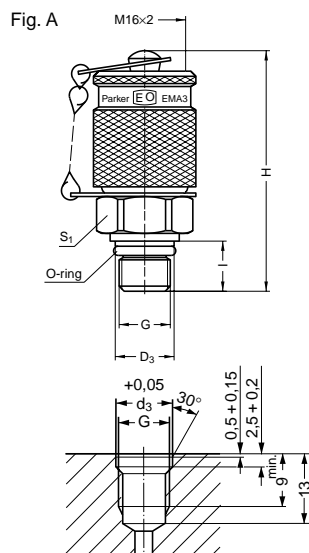

PN (bar)	P _{max} (bar)	G	S ₁	I	L	H	D ₃	Form	Part no. Steel	Part no. stainless steel
630	700	M8∞1	17	8.5		46	9.5	A	EMA3/8∞1OR	
630	700	M10∞1	17	9.8		47	11.5	A	EMA3/10∞1OR	EMA3/M10OR71
630	700	M14∞1.5	19	11.0		49	18.8	F	EMA3/14∞1.5ISO	EMA3/M14ISO71
400	630	M10∞1	17	8.0		45	14.0	D	EMA3/10∞1	
400	630	M12∞1.5	17	12.0		49	17.0	D	EMA3/12∞1.5	
400	630	M14∞1.5	19	12.0		49	19.0	D	EMA3/14∞1.5	
400	630	M16∞1.5	22	12.0		49	21.0	D	EMA3/16∞1.5	
400	630	G1/8	17	8.0		45	14.0	D	EMA3/1/8	
400	630	G1/4	19	12.0		49	18.0	D	EMA3/1/4	
400	630	G3/8	22	12.0		49	22.0	E	EMA3/3/8	
400	630	G1/2	27	14.0	24.5	49	26.0	E	EMA3/1/2	
630	700	G1/8	17	8.0		45	14.0	B	EMA3/1/8ED	EMA3/1/8ED71
630	700	G1/4	19	12.0		49	19.0	B	EMA3/1/4ED	EMA3/1/4ED71
630	700	G3/8	22	12.0		49	22.0	B	EMA3/3/8ED	EMA3/3/8ED71
630	700	M10∞1	17	10.0		47	14.0	B	EMA3/10∞1ED	EMA3/M10ED71
630	700	M12∞1.5	17	12.0		49	17.0	B	EMA3/12∞1.5ED	EMA3/M12ED71
400	630	M14∞1.5	19	12.0		49	19.0	B	EMA3/14∞1.5ED	EMA3/M14ED71

O-Ring of material NBR (steel); FPM (stainless steel)

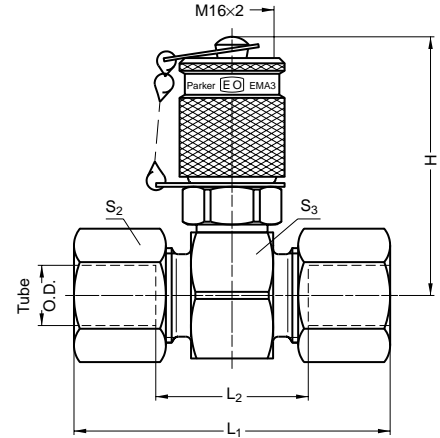
GMA 3 Straight Test Point with threaded connection M 16 \times 2

Series	PN (bar)	P _{max} (bar)	Tube O.D.	S ₂	S ₃	L ₁	L ₂	H	DPR steel	DryTechnology EO2-steel	DPR stainless steel	DryTechnology EO2-stainless steel	
L	315	500	6	14	24	51	21	49	GMA3/06L	GMA3/06ZL	GMA3/06L71	GMA3/06ZL71	
	315	500	8	17	24	51	21	49	GMA3/08L	GMA3/08ZL	GMA3/08L71	GMA3/08ZL71	
	315	500	10	19	24	53	23	49	GMA3/10L	GMA3/10ZL	GMA3/10L71	GMA3/10ZL71	
	315	400	12	22	27	53	23	50	GMA3/12L	GMA3/12ZL	GMA3/12L71	GMA3/12ZL71	
	315	400	15	27	30	55	25	52	GMA3/15L	GMA3/15ZL	GMA3/15L71	GMA3/15ZL71	
	315	400	18	32	32	57	24	53	GMA3/18L	GMA3/18ZL	GMA3/18L71	GMA3/18ZL71	
	160	250	22	36	36	61	28	55	GMA3/22L	GMA3/22ZL	GMA3/22L71	GMA3/22ZL71	
	160	250	28	41	41	61	28	57	GMA3/28L	GMA3/28ZL	GMA3/28L71	GMA3/28ZL71	
	160	250	35	50	46	69	26	60	GMA3/35L	GMA3/35ZL	GMA3/35L71	GMA3/35ZL71	
	160	250	42	60	55	71	25	64	GMA3/42L	GMA3/42ZL	GMA3/42L71	GMA3/42ZL71	
	S	630	700	6	17	24	55	25	49	GMA3/06S	GMA3/06ZS	GMA3/06S71	GMA3/06ZS71
		630	700	8	19	24	55	25	49	GMA3/08S	GMA3/08ZS	GMA3/08S71	GMA3/08ZS71
630		700	10	22	24	57	24	49	GMA3/10S	GMA3/10ZS	GMA3/10S71	GMA3/10ZS71	
630		700	12	24	24	57	24	49	GMA3/12S	GMA3/12ZS	GMA3/12S71	GMA3/12ZS71	
630		700	14	27	27	63	27	50	GMA3/14S	GMA3/14ZS	GMA3/14S71	GMA3/14ZS71	
400		630	16	30	30	63	26	52	GMA3/16S	GMA3/16ZS	GMA3/16S71	GMA3/16ZS71	
400		630	20	36	36	69	26	55	GMA3/20S	GMA3/20ZS	GMA3/20S71	GMA3/20ZS71	
400		630	25	46	41	75	27	57	GMA3/25S	GMA3/25ZS	GMA3/25S71	GMA3/25ZS71	
400		420	30	50	46	81	28	60	GMA3/30S	GMA3/30ZS	GMA3/30S71	GMA3/30ZS71	
315		420	38	60	55	91	29	64	GMA3/38S	GMA3/38ZS	GMA3/38S71	GMA3/38ZS71	

O-Ring of NBR (steel); FPM (stainless steel)

VKA 3 Test Point for cones with threaded connection M 16∞2

With 24° cone swivel nut connection

Fig. A

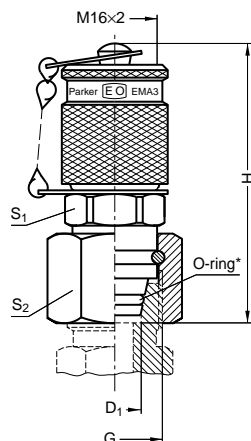
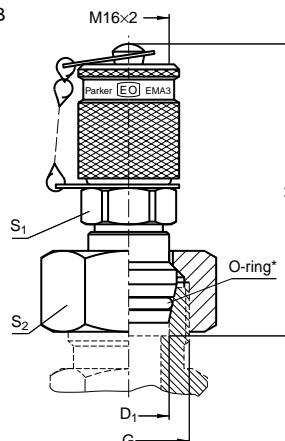

Fig. B



Series	PN (bar)	P _{max} (bar)	Tube O.D.	D ₁	G	S ₁	S ₂	H	Form	Part no. ¹ Steel	Part no. ¹ stainless steel
L	315	500	6	6	M12∞1.5	17	14	55	A	VKA3/06LA3C	VKA3/06L71
	315	500	8	8	M14∞1.5	17	17	51	A	VKA3/08LA3C	VKA3/08L71
	315	500	10	10	M16∞1.5	17	19	53	A	VKA3/10LA3C	VKA3/10L71
	315	400	12	12	M18∞1.5	17	22	53	A	VKA3/12LA3C	VKA3/12L71
	315	400	15	15	M22∞1.5	17	27	59	B	VKA3/15LA3C	VKA3/15L71
	315	400	18	18	M26∞1.5	17	32	59	B	VKA3/18LA3C	VKA3/18L71
	160	250	22	22	M30∞2	17	36	60	B	VKA3/22LA3C	VKA3/22L71
	160	250	28	28	M36∞2	17	41	64	B	VKA3/28LA3C	VKA3/28L71
	160	250	35	35	M45∞2	17	50	71	B	VKA3/35LA3C	VKA3/35L71
	160	250	42	42	M52∞2	17	60	72	B	VKA3/42LA3C	VKA3/42L71
S	630	700	6	6	M14∞1.5	17	17	50	A	VKA3/06SA3C	VKA3/06S71
	630	700	8	8	M16∞1.5	17	19	52	A	VKA3/08SA3C	VKA3/08S71
	630	700	10	10	M18∞1.5	17	22	53	A	VKA3/10SA3C	VKA3/10S71
	630	700	12	12	M20∞1.5	19	24	54	A	VKA3/12SA3C	VKA3/12S71
	630	700	14	14	M22∞1.5	17	27	59	B	VKA3/14SA3C	VKA3/14S71
	400	630	16	16	M24∞1.5	17	30	58	B	VKA3/16SA3C	VKA3/16S71
	400	630	20	20	M30∞2	17	36	65	B	VKA3/20SA3C	VKA3/20S71
	400	630	25	25	M36∞2	17	46	68	B	VKA3/25SA3C	VKA3/25S71
	400	420	30	30	M42∞2	17	50	74	B	VKA3/30SA3C	VKA3/30S71
	315	420	38	38	M52∞2	17	60	81	B	VKA3/38SA3C	VKA3/38S71

¹⁾ Supplied complete with nut.

^{*} O-ring of material NBR (steel), FPM (stainless steel).

MAV-MA 3 Test Point pressure gauge connector with threaded connection M 16∞2
MAV MD Test Point with threaded connection M 16∞2
SMA 3 Test Point high pressure hose with threaded connection M 16∞2

Female thread: BSP
 Sealing: sealing ring DIN 16258*

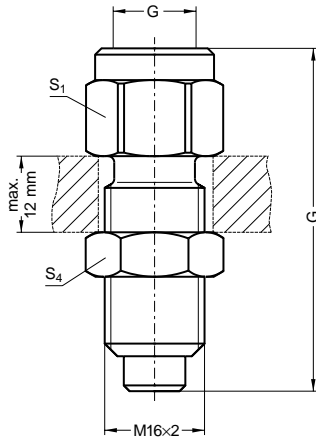

Pressure gauge connector: MAV-MA 3

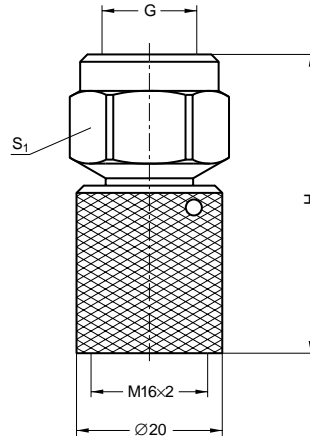

Manometer-Direct-Connector: MAVMD

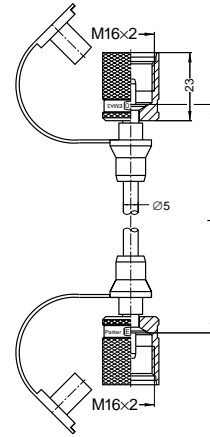

Test hose: SMA 3

PN (bar)	P _{max} (bar)	G	S ₁	S ₄	H	L	Part no.
630	700	G1/4	19	19	54.0		MAV1/4MA3
630	700	G1/2	27	19	64.0		MAV1/2MA3
630	700	G1/4	19		41.0		MAVMD1/4MA3
630	700	G1/2	27		51.5		MAVMD1/2MA3
630	700					200	SMA3-200
630	700					300	SMA3-300
630	700					400	SMA3-400
630	700					630	SMA3-630
630	700					800	SMA3-800
630	700					1000	SMA3-1000
630	700					1500	SMA3-1500
630	700					2000	SMA3-2000
630	700					2500	SMA3-2500
630	700					3200	SMA3-3200
630	700					4000	SMA3-4000

* Sealing rings according to DIN 16258 for steel design of copper, for stainless steel design of stainless steel.

For measuring with liquid pressure media please note:
Bleed before connecting tube!

Note hoses with small diameter:

- Min. bending radius $r = 20$ mm
- Working temperature -20°C up to 100°C (short time to $+120^{\circ}\text{C}$)
- Hoses are to be protected from fire, from sharp-corners and hot objects.

Temperature factor of pressur rating:

up to	0°C	122 %
for	30°C	110 %
for	50°C	100 %
for	80°C	86 %
for	100°C	77 %

SensoControl

ServicemanSeries



The SensoControl Serviceman Kits (SC-500-01, SC-510-01) are basic equipment to measure pressure, temperature, flow and rotational speed in hydraulics. Simple to operate; particularly suitable for on-site use.

All SensoControl handmeters are provided with sensor recognition. The measuring ranges are automatically scaled and shown on the display. This prevents measuring errors and makes time-consuming adjustment work unnecessary.

Please ask for catalogue no. 4087!

SensoControl

ServiceMaster Series



The ServiceMaster is a multi-channel handmeter for the simultaneous measuring of important hydraulic values: all hydraulic parameters, such as pressure, differential pressure, flow and hydraulic power can be measured, displayed, stored and processed.



SCKIT-250/350 – Basic and extended Kits in order to measure up to 3 hydraulic datas simultaneously.

SensoControl

ServiceMaster Series



SensoControl handmeters and complete measuring systems are perfectly suited measuring tools for every application. Whether they are used in the industrial area, in mobile hydraulics, for service or repair: measuring and processing of hydraulic values is the basis of safe trouble shooting. The systematic search of errors with modern means is something the service engineer simply cannot do without.

To meet the requirements in both modern industrial hydraulics and complex mobile hydraulics, we offer a range of different models.



SCKIT-400/450 – Advanced Kits for complete diagnosis including software and printer. Up to 6 channels can be measured, displayed and analyzed.

Please ask for cat. no. 4084!

SensoControl

Panel Instruments SCE



Panel mounted units for installation, designed to match the available sensor range. Depending on model, can be used to display all hydraulic parameters such as pressure, flow rate and temperature. Limit value adjustment and serial interface to PC is a standard for these instruments. All panel instruments Series SCE are operating with common electronic signals (0/4 ... 20 mA or 0 ... 10 V). Therefore they are part of the modern technology.

Data sheets 4076 and 4081 Parker, Bielefeld

SensoControl

Pressure sensors SCP



Pressure sensors in heavy-duty stainless steel design. Different male threads and electrical plug connections. Linearized output signals for measurement ranges up to 600 bar in relative or absolute versions. Also available as a combined design with pressure and temperature sensor.

Data sheet 4083 Parker, Bielefeld

SensoControl

Adaptors series SCA-EMA



Broad range of EMA measuring points and adaptors in galvanized finish for rapid, clean and simple adaption of sensors and measuring equipment to hydraulic systems. Plug and screw designs with various threads and seal forms are available. EMA measuring points can be connected under pressure.

Please ask for our SensoControl Catalogue!

SensoControl

Flow transducers and turbines



The program for flow measurement in hydraulic systems either as a turbine, a poppet type sensor with high dynamic resolution or as a gear counter for high precision measurements.

SCFT turbine:

4 measurement ranges, up to 600 l/min
high pressure resistant up to 400 bar
integrated pressure and temperature measuring points

SCQ poppet type sensor:

Quick response time < 2 ms.
High pressure resistant up to 420 bar

Gear counter SCVF:

Accuracy: $\pm 0,5\%$ FS (Full Sale)
7 measuring ranges up to 300 l/min.
High working pressure up to 315 bar.

SensoControl

Temperature sensor SCT



Temperature ranges from -25°C to $+125^{\circ}\text{C}$ can be measured with the SCT-150. The SCT can be adapted to the hydraulic system up to a pressure of 630 bar. The male stud is compatible with the test points of the GMA 3/20 series.

Please ask for our
SensoControl Catalogue!

H

