

- CV**
Check Valves
- SH**
Shuttle Valves
- LM**
Load/Motor Controls
- FC**
Flow Controls
- PC**
Pressure Controls
- LE**
Logic Elements
- DC**
Directional Controls
- MV**
Manual Valves
- SV**
Solenoid Valves
- PV**
Proportional Valves
- CE**
Coils & Electronics
- CB**
Cartridge Bodies
- BC**
Bodies & Cavities
- TD**
Technical Data

General Description

Pilot Operated Sequence Valve (Internally Piloted, Externally Drained). For additional information see Technical Tips on pages PC1-PC6.



Features

- Hardened, precision ground parts for durability
- High accuracy, pilot operation design
- Ball-type pilot for added stability
- All external parts zinc plated

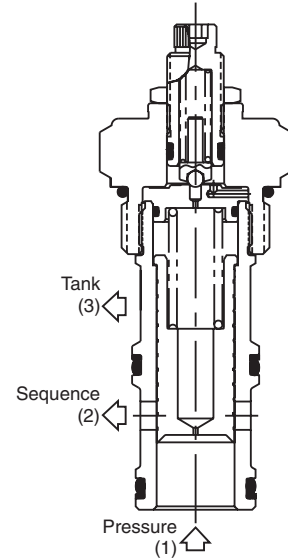
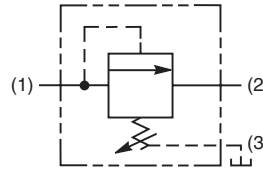

Specifications

Rated Flow	151.6 LPM (40 GPM)
Maximum Inlet Pressure	380 Bar (5500 PSI)
Maximum Pressure Setting	350 Bar (5000 PSI)
Sensitivity: Pressure/Turn	10 23 Bar (334 PSI) 30 59.7 Bar (867 PSI) 50 118 Bar (1711 PSI)
Maximum Tank Pressure	350 Bar (5000 PSI)
Maximum Drain Flow	1.9 LPM (0.5 GPM)
Reseat Pressure	80% of crack pressure
Leakage at 150 SSU (32 cSt)	5 cc per 6.8 Bar (100PSI) setting
Cartridge Material	All parts steel. All operating parts hardened steel.
Operating Temp. Range/Seals	-34°C to +121°C (Nitrile) (-30°F to +250°F) -26°C to +204°C (Fluorocarbon) (-15°F to +400°F)
Fluid Compatibility/Viscosity	Mineral-based or synthetic with lubricating properties at viscosities of 45 to 2000 SSU (6 to 420 cSt)
Filtration	ISO-4406 18/16/13, SAE Class 4
Approx. Weight	0.45 kg (1.0 lbs.)
Cavity	C16-3 (See BC Section for more details)
Form Tool	Rougher NFT16-3R Finisher NFT16-3F

Performance Curve

Flow vs. Inlet Pressure

(Pressure rise through cartridge only)

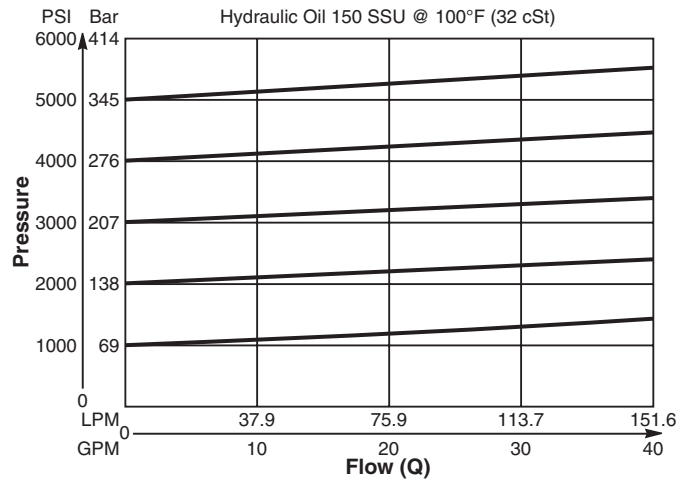

Dimensions Millimeters (Inches)

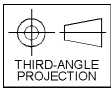
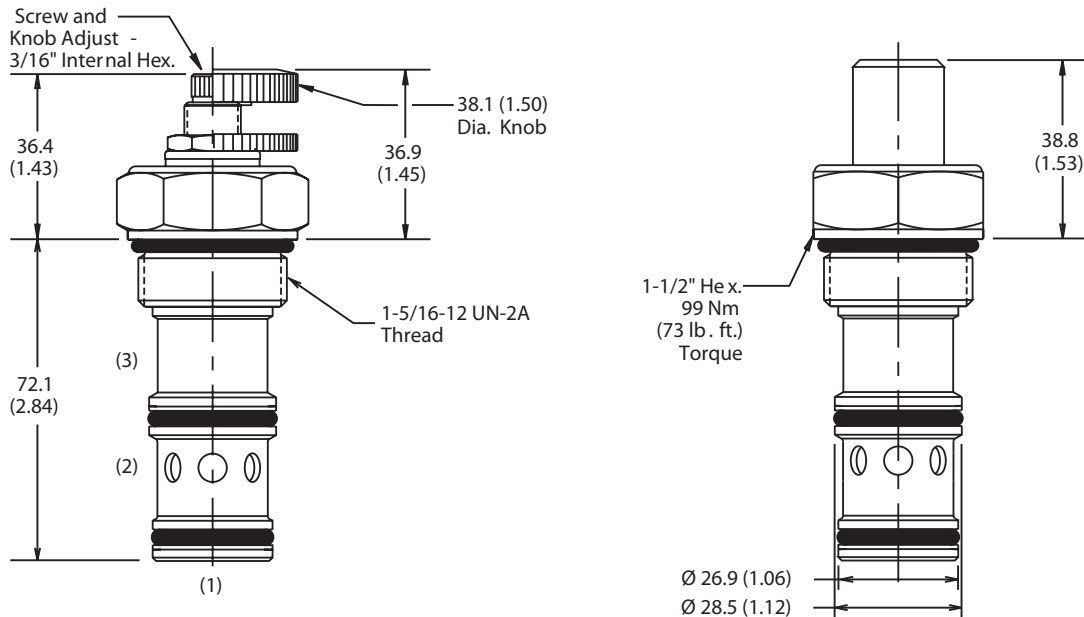

Screw/Knob Version

Tamper Resistant Version

Ordering Information

SVH161	<input type="checkbox"/>	<input type="checkbox"/>	<input type="checkbox"/>
16 Size P.O. Sequence Valve (Internal Pilot)	Adjustment Style	Pressure Range	Seals

Highlighted represents preferred options that offer the shortest lead times. Other options may be available, but at extended lead times.

Code	Adjustment Style / Kit No.
K	Knob Adjust (717784-15)
S	Screw Adjust
T	Tamper Resistant Cap (717785)

Code	Seals / Kit No.
Omit	Nitrile / (SK16-3)
V	Fluorocarbon / (SK16-3V)

Code	Pressure Range
10	6.9 - 69 Bar (100 - 1000 PSI) Standard Setting: 34.5 Bar (500 PSI) @ 11.3 LPM (3 GPM)
30	20.7 - 207 Bar (300 - 3000 PSI) Standard Setting: 103.5 Bar (1500 PSI) @ 11.3 LPM (3 GPM)
50	34.5 - 345 Bar (500 - 5000 PSI) Standard Setting: 172.4 Bar (2500 PSI) @ 11.3 LPM (3 GPM)

Order Bodies Separately
 See section BC

B16	-	3	-	<input type="checkbox"/>
16 size		3-Way Cavity		Port Size

Code	Porting / Body Material
16T	SAE-16 / Steel (5000 PSI)
A16T	SAE-16 / Aluminium (3000 PSI)

CV
Check Valves
SH
Shuttle Valves
LM
Load/Motor Controls
FC
Flow Controls
PC
Pressure Controls
LE
Logic Elements
DC
Directional Controls
MV
Manual Valves
SV
Solenoid Valves
PV
Proportional Valves
CE
Coils & Electronics
CB
Cartpak Bodies
BC
Bodies & Cavities
TD
Technical Data