

Pilot operated check valves series RH allow free flow in one direction (B to A). The counter flow is blocked (A to B). By applying pilot pressure the ball can be lifted from its seat and allow flow from A to B.

Most common use:

- Keeping cylinders leak-free in position, when spool type directional control valves are used
- Return line discharge, when return flow exceeds functional limits of directional control valve at differential cylinders
- As hydraulically activated drain or circulation valve

The valves are available without and with hydraulic pre-discharging.

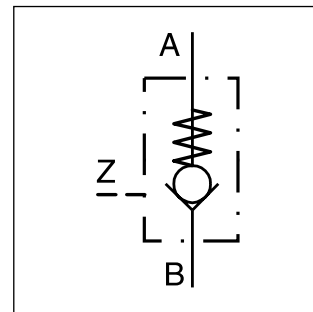

**Without pre-discharging**

These valves have a ball as valve element, which quickly enables the full flow cross-section proportionally during pilot operation. A metering position in the pilot port dampens the control movement of the pilot spool so that pressure shocks (unloading shocks) are mostly suppressed.

**With pre-discharging**

For valves with pre-discharging a spherical polished valve spool (seat valve function) is built-in instead of a ball. The additional check valve achieves a pre-opening which provides shock-free unloading of the fluid, especially at high working pressure and large volumes.

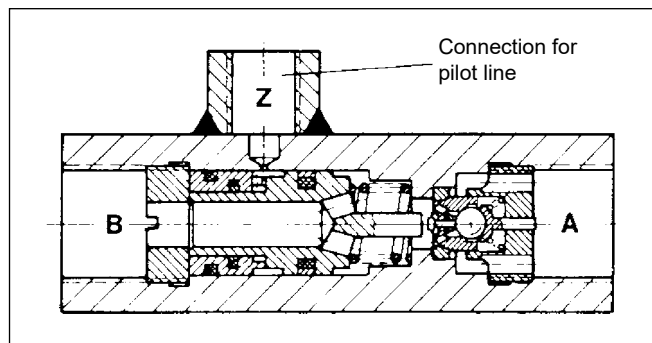
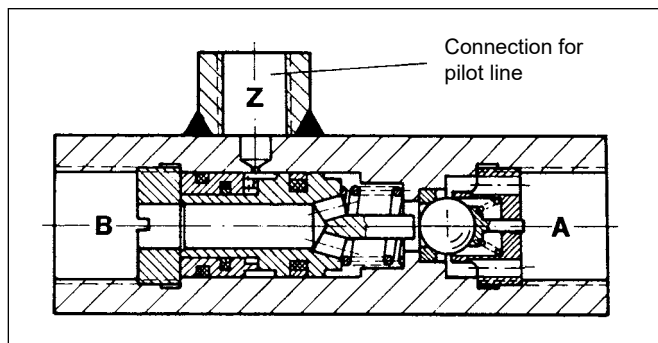

**Ordering code**

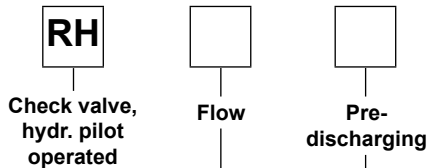

Code	Flow [l/min]
1	15
2	35
3	55
4	100

Code	Pre-discharging
<b>v</b> <sup>1)</sup>	<b>with</b>
omit	<b>without</b>

**Bold letters = Short-term availability**

<sup>1)</sup> Only for sizes 3 and 4

**Technical data**

General						
Code		RH	<b>1</b>	<b>2</b>	<b>3 / 3V</b>	<b>4 / 4V</b>
Pipe connections	DIN ISO 228/1 A, B DIN ISO 228/1 Z		G ¼ G ¼	G ¾ G ¼	G ½ G ¼	G ¾ G ¼
Mounting	Freely suspended in the pipeline					
Mounting position	unrestricted					
Ambient temperature		[°C]	-20 ... +60			
MTTF <sub>D</sub> value		[years]	150			
Weight		[kg]	0.4	0.4	0.6	1.3
Hydraulic						
Max. operating pressure		[bar]	700	700	500	500
Flow approx.		[l/min]	15	35	55	100
Pilot flow volume		[cm³]	0.15	0.22	0.4	1
Fluid	Hydraulic oil according to DIN 51524					
Fluid temperature		[°C]	-20...+70			
Viscosity	permitted	[cSt]/[mm²/s]	20...400			
	recommended	[cSt]/[mm²/s]	30...80			

**Pilot pressure  $p_{St}$  for pilot operation of the main valve**  
 ( $p_B = 0$  bar)

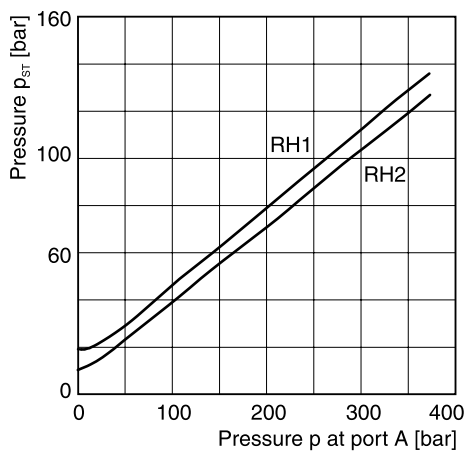

**Pilot pressure  $p_{St}$  for pilot operation of pre-discharging**

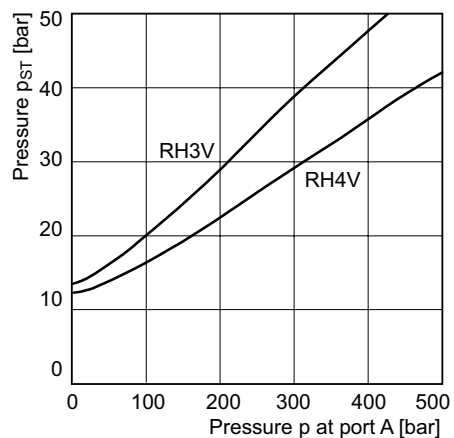

for keeping open	
$p_{St}$	$p_B + \Delta p + k$
$p_B$ [bar]	pressure on side B
$\Delta p$ [bar]	flow resistance A to B as per $\Delta p/Q$ performance curve
$k$	10 at RH 1 and RH 2 7 at RH 3 V 8 at RH 4 V

**Performance  $\Delta p/Q$  curves** (valid for flow polarity B to A and pilot operated direction A to B)

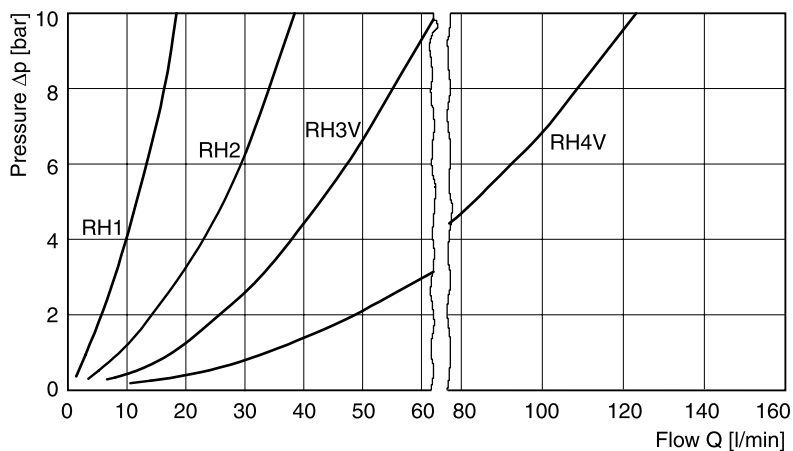

Opening pressure B to A 0.2...0.3 bar

Oil viscosity during the measurement, 60 mm<sup>2</sup>/s

For viscosities over approx. 500 mm<sup>2</sup>/s, a strong  $\Delta p$ -increase is to be expected for smaller types (RH1...RH3).

**Dimensions**

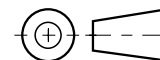
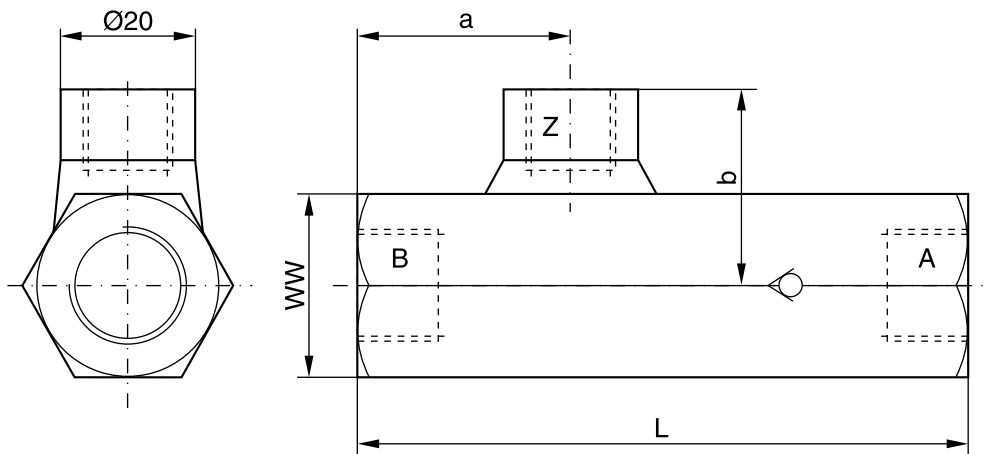

Type	Port <sup>1)</sup>		L	a	b	SW
	A, B	Z				
RH 1	G ¼	G ¼	84	31.5	27	24
RH 2	G ⅜	G ¼	90	32	28.5	27
RH 3 V	G ½	G ¼	100	36.5	31	32
RH 4 V	G ¾	G ¼	126	45	35.5	41

<sup>1)</sup> As per DIN 228/1, suitable for pipe connections with thread studs form B as per DIN 3852 page 2.