

Characteristics

**Pilot Operated Prop. Pressure Relief Valves
Series R4V / R6V (Proportional)**

Pilot operated proportional pressure relief valves series R4V (DIN 24340 Form D) and R6V (DIN 24340 Form E) consist of a proportionally adjusted pilot stage and a seated type main stage.

The optimum performance can be achieved in combination with the digital amplifier module PCD00A-400.

Features

- Pilot operated with proportional solenoid
- 2 interfaces:
 - R4V subplate ISO 6264 (DIN 24340 Form D)
 - R6V subplate ISO 6264 (DIN 24340 Form E)
- 3 pressure stages
- Mechanical maximum pressure adjustment (optional for R6V)



R6V06



R4V06

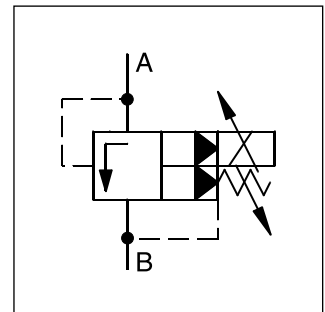
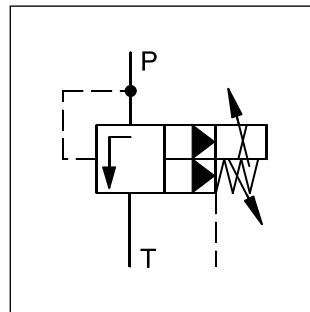

4

R6V06

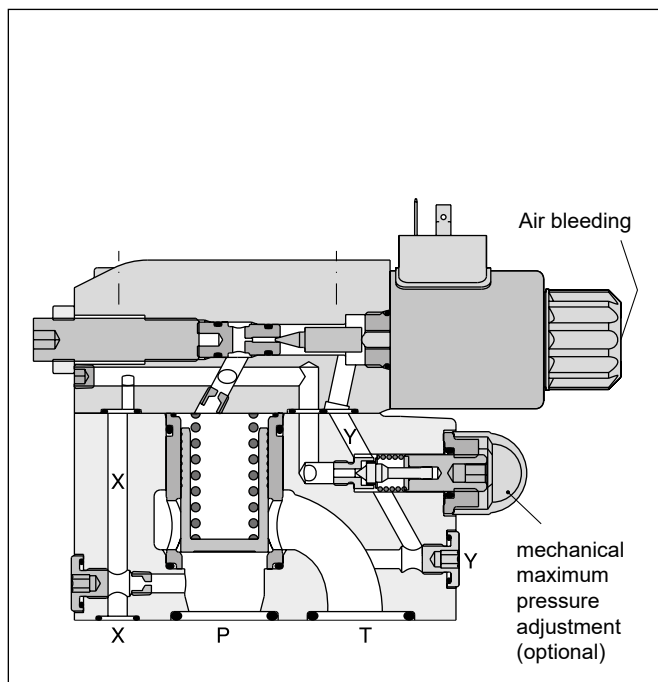

R4V06

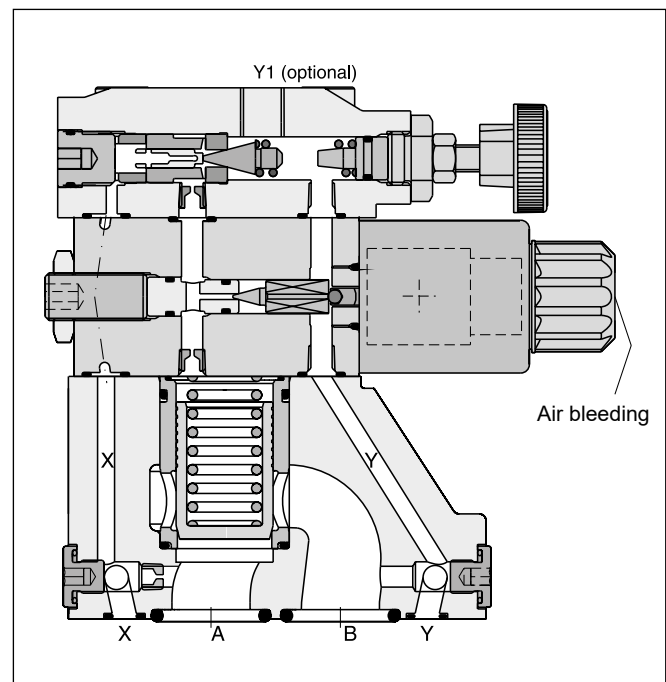

4

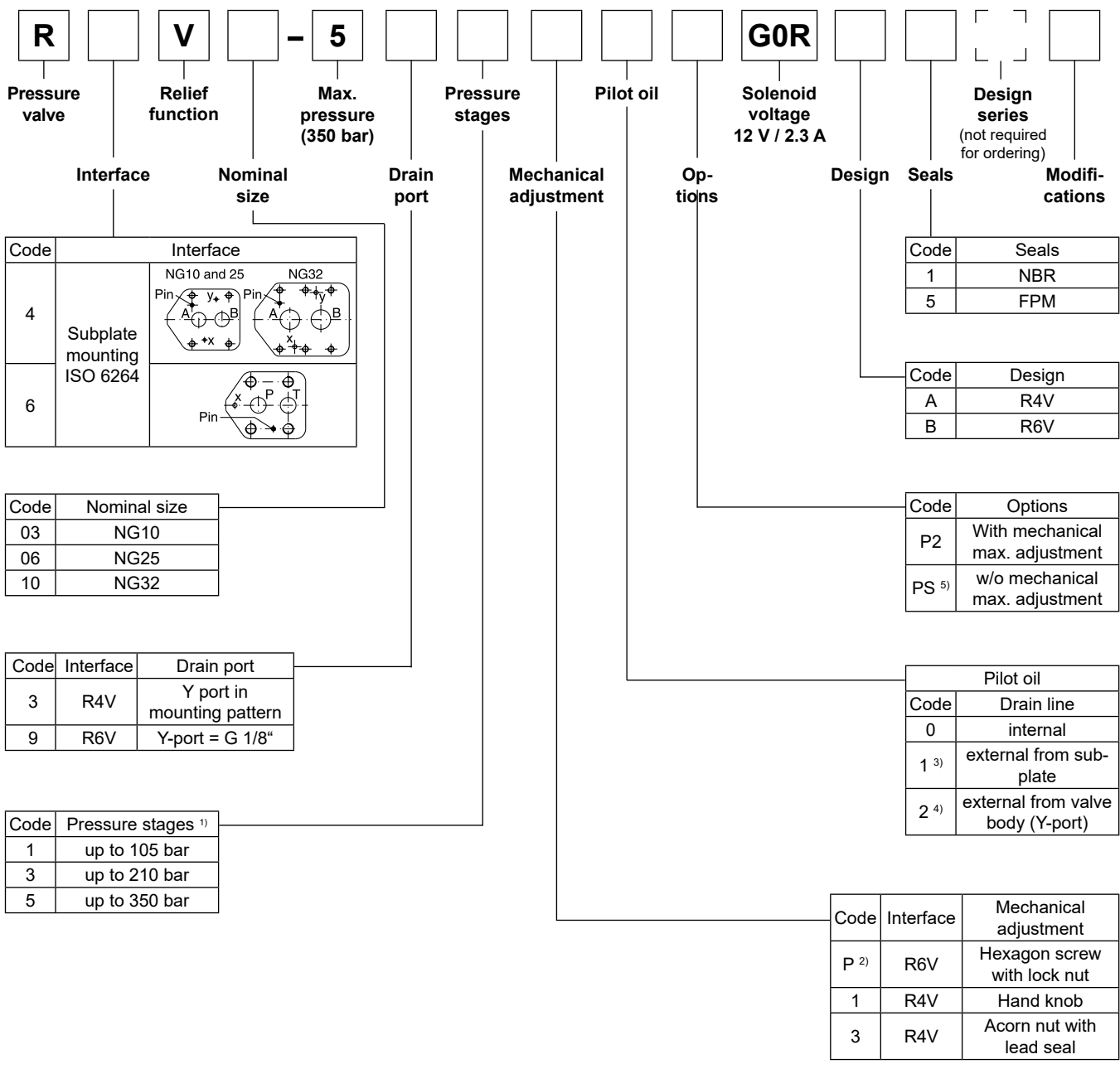

¹⁾ Other pressure stages on request.

²⁾ Use code P also for valve w/o mechanical adjustment.

³⁾ R4V only.

⁴⁾ R6V only.

⁵⁾ Not for R4V.

Technical Data

General					
Nominal size			10	25	32
Interface	Subplate mounting acc. ISO 6264				
Mounting position	Unrestricted, horizontal mounting preferred				
Ambient temperature	[°C]	-20...+60			
MTTF _D value	[years]	75			
Weight	Series R4V	[kg]	4.5	6.3	7.8
	Series R6V	[kg]	5.2	6.4	8.3
Hydraulic					
Max. operating pressure	[bar]	Ports P (or A) and X up to 350, port T (or B) and Y 30			
Pressure stages	[bar]	105, 210, 350			
Nominal flow	Series R4V	[l/min]	90	300	600
	Series R6V	[l/min]	250	500	650
Fluid	Hydraulic oil according to DIN 51524				
Viscosity, permitted	[cSt] / [mm ² /s]	20 ... 400			
	recommended	[cSt] / [mm ² /s]	30 ... 80		
Fluid temperature	[°C]	-20...+70 (NBR: -25...+70)			
Filtration	ISO 4406 (1999); 18/16/13				
Electrical (prop. solenoid)					
Duty ratio	[%]	100 ED; CAUTION: coil temperature up to 150 °C possible			
Protection class	IP65 in accordance with EN 60529 (with correctly mounted plug-in connector)				
Supply voltage	[V]	12 V =			
Max. current	[A]	2.1			
Coil resistance at 20 °C	[Ohm]	4.28			
Solenoid connection	Connector as per EN 175301-803				
Power amplifier, recommended	PCD00A-400				

4

R4V Signal/pressure curve

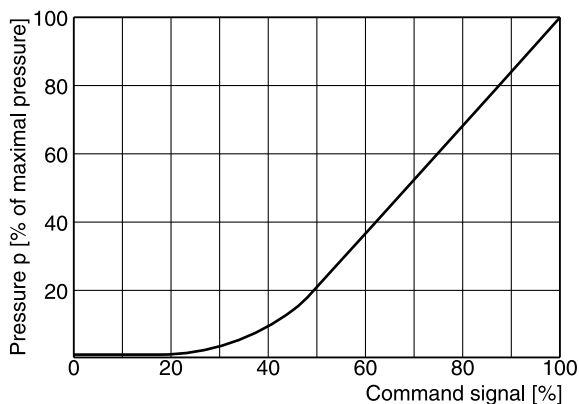

R6V Signal/pressure curve

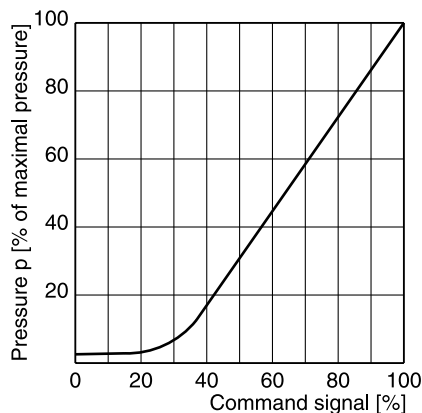

p/Q performance curves ¹⁾

R4V / R6V03

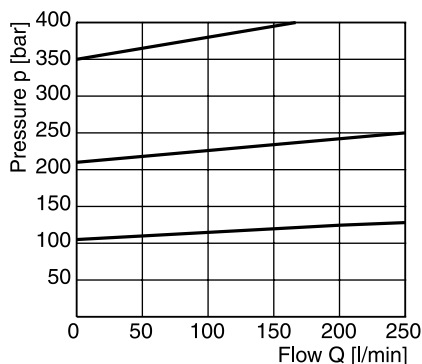

R4V / R6V06

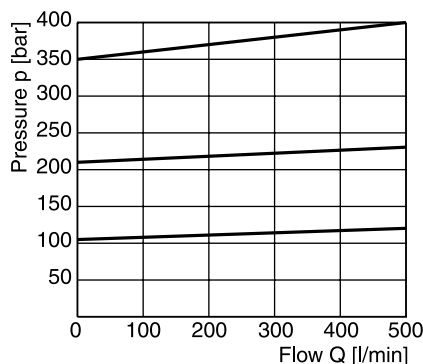

R4V / R6V10

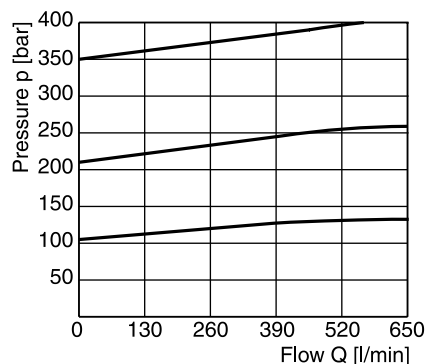

Minimum pressure curves ¹⁾

R4V / R6V03

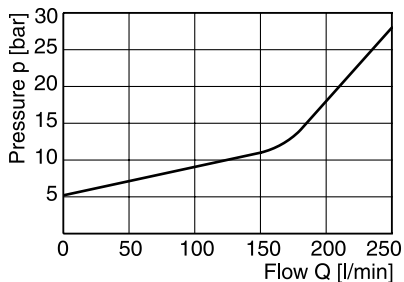

R4V / R6V06

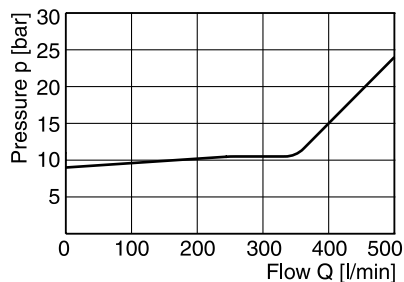

R4V / R6V10

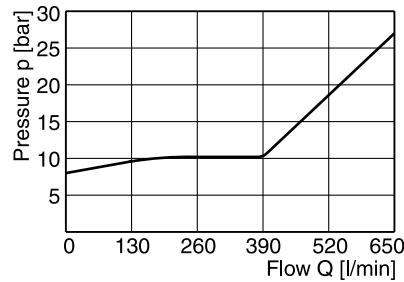

All characteristic curves measured with HLP46 at 50 °C.

¹⁾ The performance curves are measured with external drain.
 For internal drain the tank pressure has to be added to curve.

R4V

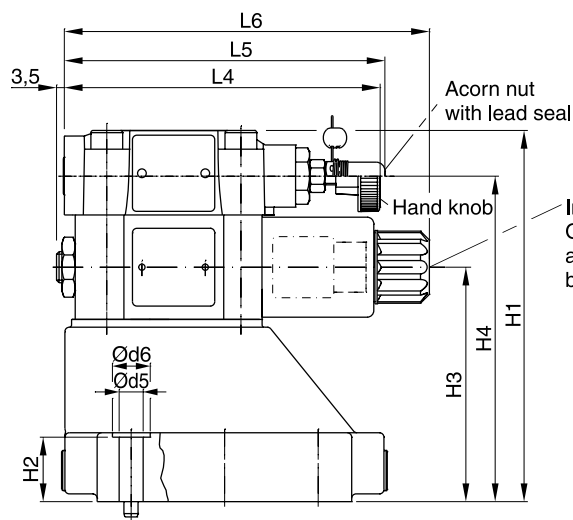
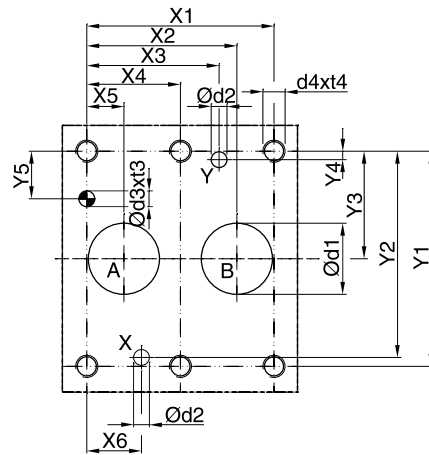
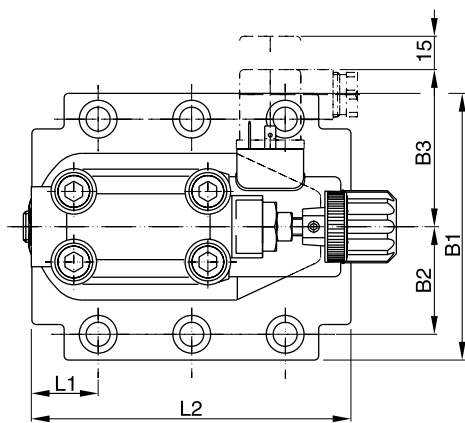

Important:
 On initial start up
 and after long shut down periods
 bleed air from this plug.

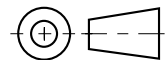

NG	ISO-code	x1	x2	x3	x4	x5	x6	x7	y1	y2	y3	y4	y5	y6
10	6264-06-07-*-97	42.9	35.8	21.5	–	7.2	21.5	0	66.7	58.8	33.4	7.9	14.3	–
25	6264-08-11-*-97	60.3	49.2	39.7	–	11.1	20.6	0	79.4	73	39.7	6.4	15.9	–
32	6264-10-15-*-97	84.2	67.5	59.5	42.1	16.7	24.6	0	96.8	92.8	48.4	3.8	21.4	–

Tolerance at X and Y pin holes and screw holes ±0.1, at port holes ±0.2.

NG	ISO-code	B1	B2	B3	H1	H2	H3	H4	H6	L1	L2	L3	L4	L5	L6
10	6264-06-07-*-97	87.3	33.35	71	130	21	68.5	109.5	–	25	90.8	–	143	144.8	164.8
25	6264-08-11-*-97	105	39.7	71	154.5	29	93	134	–	30.9	123	–	143	144.8	164.8
32	6264-10-15-*-97	120	48.4	71	167	30	105.5	146.5	–	29.8	143.5	–	143	144.8	164.8

NG	ISO-code	d1max	d2max	d3	t3	d4	t4	d5	d6	Subplate ¹⁾
10	6264-06-07-*-97	15	7	7.1	8	M10	16	10.8	17	SPP 3M6B 910
25	6264-08-11-*-97	23.4	7.1	7.1	8	M10	18	10.8	17	SPP 6M8B 910
32	6264-10-15-*-97	32	7.1	7.1	8	M10	20	10.8	17	SPP 10M12B 910

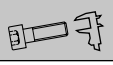
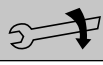
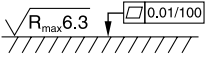
NG	Bolt kit			Kit		Surface finish
				NBR	FPM	
10	BK505	4x M10x35 ISO 4762-12.9	63 Nm ±15 %	S26-58507-0 ²⁾	S26-58507-5 ²⁾	
25	BK485	4x M10x45 ISO 4762-12.9	63 Nm ±15 %	S26-58475-0 ²⁾	S26-58475-5 ²⁾	
32	BK506	4x M10x45 ISO 4762-12.9	63 Nm ±15 %	S26-58508-0 ²⁾	S26-58508-5 ²⁾	
Prop. section P2				S26-58473-0	S26-58473-5	

¹⁾ Details see chapter 12, series SPP.

²⁾ Please combine seal kit of one size with seal kit of prop. section P2 for complete seal kit.

R6V

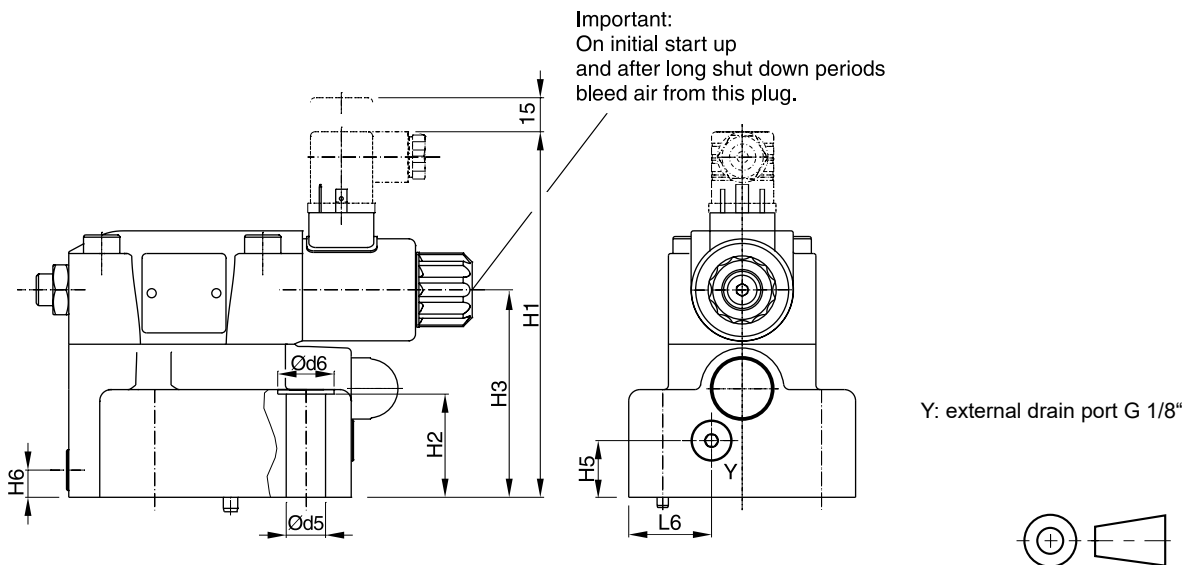
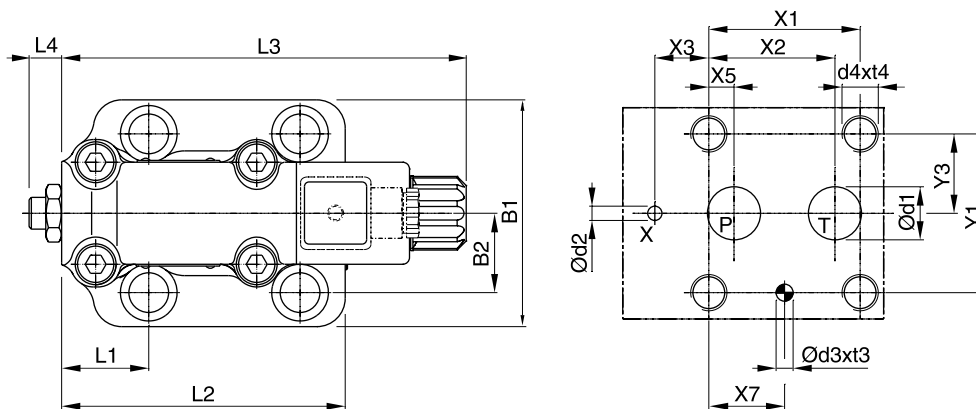



NG	ISO-code	x1	x2	x3	x4	x5	x6	x7	y1	y2	y3	y4	y5	y6
10	6264-06-09-*-97	53.8	47.5	0	-	22.1	-	22.1	53.8	-	26.9	-	-	-
25	6264-08-13-*-97	66.7	55.6	23.8	-	11.1	-	33.4	70	-	35	-	-	-
32	6264-10-17-*-97	88.9	76.2	31.8	-	12.7	-	44.5	82.6	-	41.3	-	-	-

Tolerance at X and Y pin holes and screw holes ± 0.1 , at port holes ± 0.2 .

NG	ISO-code	B1	B2	H1	H2	H3	H4	H5	H6	L1	L2	L3	L4	L5	L6
10	6264-06-09-*-97	80	26.9	158.7	27	88	-	20.5	25	52	117	182.3	14.4	-	29.5
25	6264-08-13-*-97	100	35	161.2	46.5	91.5	-	25	12	37.9	124.5	182.3	14.4	-	36.5
32	6264-10-17-*-97	120	41.3	166.7	51.3	98.5	-	26.5	13.5	44.3	153	182.3	14.4	-	46.5

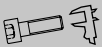
NG	ISO-code	d1max	d2max	d3	t3	d4	t4	d5	d6	Subplate ¹⁾
10	6264-06-09-*-97	14.7	4.8	7.5	10	M12	20	13.5	20	SPP 3R6B 910
25	6264-08-13-*-97	23.4	6.3	7.5	10	M16	27	17.5	25	SPP 6R10B 910
32	6264-10-17-*-97	32	6.3	7.5	10	M18	28	20	30	SPP 10R12B 910

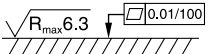
NG	Bolt kit			Kit		Surface finish
				NBR	FPM	
10	BK494	4x M12x45 ISO 4762-12.9	108 Nm ± 15 %	S26-98589-0	S26-98589-5	
25	BK366	4x M16x70 ISO 4762-12.9	264 Nm ± 15 %	S26-96396-0	S26-96396-5	
32	BK507	4x M18x75 ISO 4762-12.9	398 Nm ± 15 %	S26-96392-0	S26-96392-5	

¹⁾ Details see chapter 12, series SPP.