

**General Description**

2-Way Poppet Valves. For additional information see Technical Tips on pages SV1-SV5.



**Features**

- Replaceable, one piece encapsulated coils with minimal amperage draw
- Various coil terminations and voltages
- Various manual override options
- Fast response available, (CH and CHR) rated at 30 LPM (8 GPM)
- Polyurethane “D”-Ring eliminates need for backup rings
- Nylon inserted jam-nut provides secure holding in high vibration applications
- All external parts zinc plated

**Specifications**

Rated Flow	60 LPM (15 GPM)		
Maximum Inlet Pressure	350 Bar (5000 PSI)		
Leakage at 150 SSU (32 cSt)	5 drops/min. (.33 cc/min.)		
Minimum Operating Voltage	85% of rated voltage at 20°C (72°F).		
Response Time		<b>Energized</b>	<b>De-Energized</b>
	<b>C, CR</b>	80 ms	150 ms
	<b>CH, CHR</b>	50 ms	50 ms
	<b>N, NR</b>	70 ms	35 ms
Cartridge Material	All parts steel. All operating parts hardened steel.		
Operating Temp. Range/Seals	-37°C to +93°C (“D”-Ring) (-35°F to +200°F) -34°C to +121°C (Nitrile) (-30°F to +250°F) -26°C to +204°C (Fluorocarbon) (-15°F to +400°F)		
Fluid Compatibility/Viscosity	Mineral-based or synthetic with lubricating properties at viscosities of 45 to 2000 SSU (6 to 420 cSt)		
Filtration	ISO 4406 18/16/13, SAE Class 4		
Approx. Weight	.20 kg (0.41 lbs.)		
Cavity	C10-2 (See BC Section for more details)		
Form Tool	Rougher Finisher	None	NFT10-2F

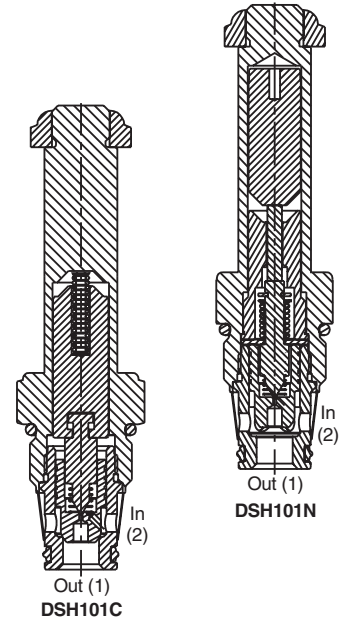
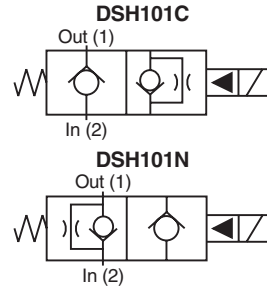

**Performance Curves**

Pressure Drop vs. Flow (Through cartridge only)

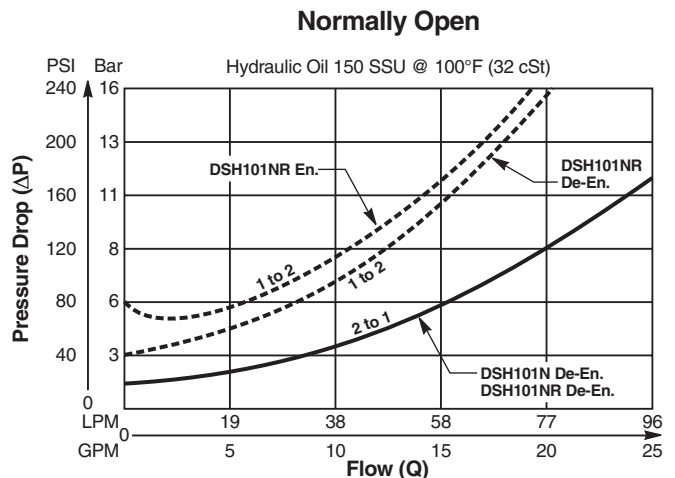
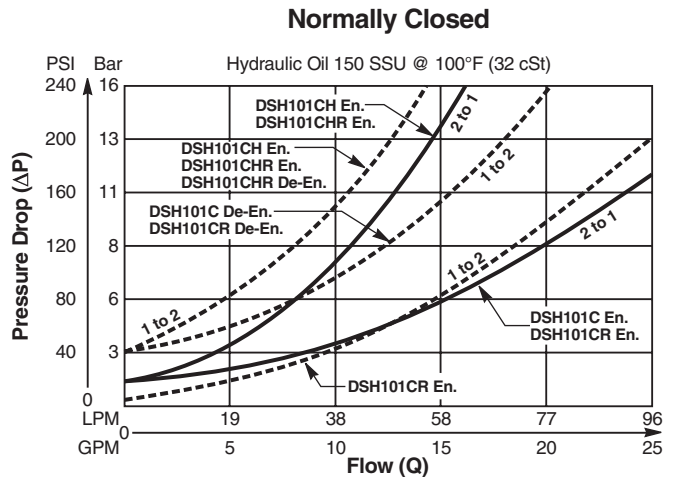

**Dimensions** Millimeters (Inches)

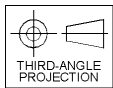
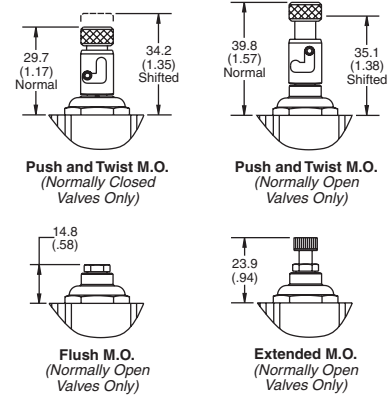
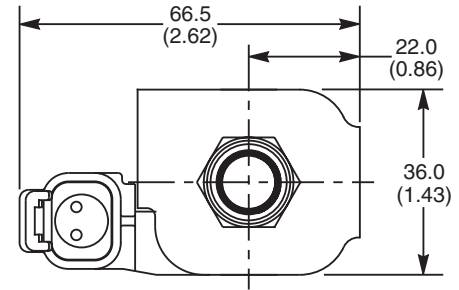
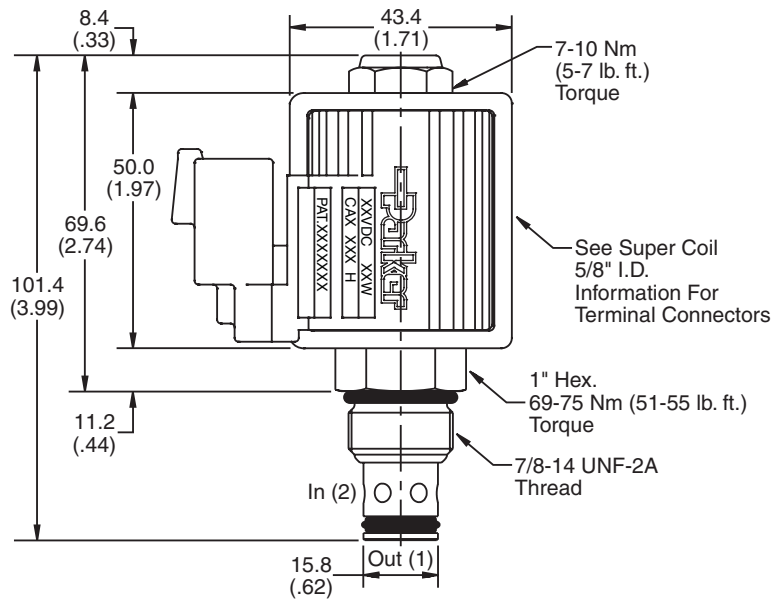

**Ordering Information**

**DSH101**                   

**10 Size Solenoid Valve**    **Style**    **Override Option**    **Seals**    **Screen**

**Highlighted** represents preferred options that offer the shortest lead times. Other options may be available, but at extended lead times.

**Coil(s) sold separately.** Please see section CE of this catalog, 5/8" Super-Coil (CA series), for ordering information.

*Order Bodies Separately  
 See section BC*

**B10** - **2** -

10 size    2-Way Cavity    Port Size

Code	Port Size / Body Material
8T	SAE-8 / Steel (5000 PSI)
A8T	SAE-8 / Aluminium (3000 PSI)

Code / Style	Diagram
<b>C</b> Normally Closed Metered reverse flow	
<b>CH</b> Normally Closed Metered reverse flow (Fast response)	
<b>CHR</b> Normally Closed Free reverse flow (Fast response)	
<b>CR</b> Normally Closed Free reverse flow	
<b>N</b> Normally Open Metered reverse flow	
<b>NR</b> Normally Open Free reverse flow	

Code	Override Options
<b>Omit</b>	<b>None</b>
E	Push Type with Extended Rod (N.O. Only)
M	Push Type with Flush Rod (N.O. Only)
T	Push & Twist (N.C. & N.O.)

Code	Seals / Kit No.
<b>Omit</b>	<b>"D"-Ring / (SK10-2)</b>
N	Nitrile (SK10-2)
V	Fluorocarbon / (SK10-2V)

Code	Screen
<b>Omit</b>	<b>None</b>
S	Screen



**CV**  
Check Valves

**SH**  
Shuttle Valves

**LM**  
Load/Motor Controls

**FC**  
Flow Controls

**PC**  
Pressure Controls

**LE**  
Logic Elements

**DC**  
Directional Controls

**MV**  
Manual Valves

**SV**  
Solenoid Valves

**PV**  
Proportional Valves

**CE**  
Coils & Electronics

**CB**  
Cartrpак Bodies

**BC**  
Bodies & Cavities

**TD**  
Technical Data